

IMPORTANT NOTICE

- Read the Manual in Full First
- Always use an Inlet Filter to Prevent Foreign Matter from Entering the Pump
- Purge After Every Process
- Always Return V2 to the Recovery Position After Purge
- Avoid Flooding the Compressor by Slowly Opening V1 During Recovery or Purge

Thank you for buying the JAVAC Xtract-R™ Refrigerant Recovery Machine!

Xtract-R combines an innovative refrigerant gas compression system with a rugged, moulded case that is designed to offer maximum protection from damage during transit and normal handling. With normal use and with care as prescribed in this Manual, your Xtract-R will give you years of trouble-free operation.

Safety First!



When found on the machine, this international symbol is intended to alert the user to the presence of important operating, safety and maintenance (servicing) instructions in this Manual. As used in the Manual, it is intended to draw your attention to critical items.

It is important to read this entire Manual and be familiar with its contents before using the machine!

The Xtract-R is a Recovery Machine for a broad range of refrigerants. Recovering refrigerants into a separate storage cylinder involves a process of gas compression, resulting in high pressures within the machine, the connecting hoses and the storage cylinder. High-pressure systems must always be treated with care and respect to prevent careless accidents.

EPA Certification:

The Javac Xtract-R is an EPA Certified machine in accordance with Section 608 of the Clean Air Act. It has been independently tested and verified to be in conformance with its published specifications by the Air-Conditioning & Refrigeration Institute (USA).

Product Safety:

The Javac Xtract-R has been designed to meet the requirements of the Standard for Refrigerant Recovery Machines, UL1963 and AS4211.3 - 1996. In order to fully meet safety requirements, the recovery operation must always be performed using an approved storage cylinder with a shutoff switch which is properly connected to the Xtract-R's Over Fill Protection circuit (available as an option kit). If an approved cylinder with overfill is not available always use an approved scale to monitor the cylinders capacity. Additionally, approved refrigerant hoses must be used which have shut-off devices within 12 inches of the ends to reduce the likelihood of refrigerant leakage to the atmosphere when changing cylinders or setups.

Responsibility:





A Qualified Technician who has been properly trained in the care and use of such equipment and in the recovery process itself must only operate the JAVAC Xtract-R. Use of this equipment by unqualified personnel is potentially dangerous and should not be attempted.

TABLE OF CONTENTS

SECTION AND DESCRIPTION:

- 1.0 SAFETY PRECAUTIONS**
- 2.0 SPECIFICATIONS, FEATURES AND WARRANTY**
- 3.0 SET UP AND OPERATION**
 - 3.1 GETTING STARTED**
 - 3.2 NORMAL RECOVERY OPERATION**
 - 3.3 PURGING THE SYSTEM**
 - 3.4 PUSH PULL OPERATION**
 - 3.5 COOLING THE RECOVERY CYLINDER**
 - 3.6 SPECIAL OPERATING NOTES**
 - 3.7 STORAGE**
- 4.0 APPROVED ACCESSORY ITEMS**
- 5.0 MAINTENANCE**
- 6.0 TROUBLESHOOTING**
- 7.0 SERVICE - CONSTRUCTION AND SCHEMATIC**
- 8.0 RECOVERY CYLINDER SAFETY**

1.0 SAFETY PRECAUTIONS:

- 1.1  **THIS EQUIPMENT MUST ALWAYS BE OPERATED BY A QUALIFIED TECHNICIAN WHO IS FAMILIAR WITH REFRIGERANT SYSTEMS, REFRIGERANTS, REFRIGERANT SAFETY AND LAWS PERTAINING TO REFRIGERANT USEAGE.**
- 1.2  **READ THIS MANUAL** and become familiar with the specifications and operation of this machine prior to use.
- 1.3  **WEAR APPROPRIATE SAFETY PROTECTION APPAREL** such as gloves, eye protection and foot protection when working on refrigeration systems.
- 1.4  **REFRIGERANT VAPOR CAN BE HAZARDOUS AND ITS BYPRODUCTS CAN BE LETHAL** - work only in well ventilated areas. When working indoors, ensure there is adequate airflow in the work space and install a separate circulation fan if necessary. **DO NOT WORK IN AN ENCLOSED AREA** without special safety equipment as appropriate for the conditions.
- 1.5 **KNOW THE PROPER SAFETY AND HANDLING REQUIREMENTS** for the Refrigerant being recovered by reviewing manufacturer's data sheets and the Temperature - Vapour Pressure information.
- 1.6 **PERFORM LEAK DETECTION** in accordance with recommended practice only. For best results use only a refrigerant detector such as the **JAVAC D-TEK** or **TEK-Mate**. **NEVER USE OXYGEN** for this process as it can become an explosive mixture in the presence of oil and pressure.
- 1.7  **NEVER OVERFILL A STORAGE CONTAINER.** The safest approach is to use a **certified storage cylinder with a "Cylinder Full" cutoff switch** that is properly connected to the Xtract-R's optional Over Fill Protection Circuit. If the storage cylinder does not have a cutoff switch, or if **PUSH-PULL OPERATION** is used, the use of a refrigerant scale, such as the **Javac Wey-TEK**, is required to prevent overfill. **OVERFILLED CYLINDERS CAN RUPTURE EXPLOSIVELY!**
- 1.8 **STORE REFRIGERANTS** in a cool, dry place.
- 1.9 **SEPARATE DIFFERENT REFRIGERANTS.** Avoid mixing refrigerants by using separate storage cylinders and filters for each type recovered.

- 1.10 OPEN SERVICE OR CYLINDER VALVES SLOWLY** to ensure that all connections are tight and there is no danger.



- 1.11 DISCONNECT POWER** before moving or servicing the JAVAC Xtract-R. **CAUTION - only a technically qualified person who has been trained in basic electronics and refrigeration should open this unit. The risk of ELECTRIC SHOCK and exposure to HOT compressor parts is possible if the unit is opened.**



- 1.12 WARNING - TO REDUCE THE RISK OF FIRE, EXTENSION CORDS SHOULD NOT BE USED** with this equipment as the wiring can overheat under conditions of high current draw. If an extension cord is absolutely necessary, its length should be as short as possible and it should contain size 16 AWG (1.291 MM) or larger wiring.



- 1.13 FLAMMABLE ENVIRONMENTS ARE DANGEROUS** when any machine is used because motors and switches can generate sparks. This equipment should be used in locations with mechanical ventilation providing at least four air changes per hour. **DO NOT USE THIS EQUIPMENT IN THE VICINITY OF SPILLED OR OPEN CONTAINERS OF GASOLINE OR ANY OTHER FLAMMABLE LIQUID.**

- 1.14 MOISTURE** can cause severe damage when introduced to the internal parts of a refrigeration system. Ensure that care is exercised in the leak detection, recovery, repair and refilling of a system to prevent moisture from entering. Always use a quality high vacuum pump such as a Javac Deluxe to ensure the system is totally dehydrated. An electronic total pressure gauge such as the Acravac should also be used to monitor the pressure.



- 1.15 USE CAUTION WHEN OPERATING OUTDOORS.** Be certain that the power cord, the cylinder safety cord and the unit itself are not placed in water or other potentially dangerous locations. While the Xtract-R is very safe to operate, environments such as hard rain or severe wind-driven sand can lead to operator carelessness and should be avoided.



- 1.16 CAUTION - EXERCISE CARE WHEN MOVING** the equipment to prevent the risk of injury.

2.0 SPECIFICATIONS, FEATURES AND WARRANTY

2.1 Xtract-R SPECIFICATIONS:

- 2.1.1 Refrigerants: For use with any Refrigerant with a Vapour Pressure at 40⁰ C that is less than 2500 Kpa.
- 2.1.2 Power: 220/240 VAC, 50/60 Hz, 7 A
- 2.1.3 Compressor: 1/3 HP Oil less, No inlet valve, DC Motor Drive
- 2.1.4 Cooling: Custom Fan/Motor
- 2.1.5 Protection: High Pressure Switch Cut-off at 3000 Kpa (latching)
Compressor protected by separate circuit breaker
Cooling fan motor thermally protected
80% Cylinder Full Shutoff available option
- 2.1.6 Pressure: Low side design pressure 1600 Kpa;
High side design pressure 3000 Kpa
- 2.1.7 Temperature: Operating Range 10⁰ to 40⁰ C
- 2.1.8 Case: Blow-Moulded, High Impact Strength
- 2.1.9 Size: 590mm L X 44mm W X 710mm H
- 2.1.10 Weight: 14 kg
- 2.1.11 Performances as per ARI 740-95 :

<i>Refrigerant</i>	<i>Liquid Rate (kg/hr)</i>	<i>Vapour Rate (kg/hr)</i>	<i>Push / Pull Rate. (kg/hr)</i>	<i>Shut Off Vacuum (mm Hg)</i>	<i>Residual Trapped Refrigerant (kg)</i>
R-22	60	9	280	250	<0.1
R-134a	52	7	230	250	<0.1
R- 410A	44	10	350	250	<0.1

Note: In most cases recovery will exceed these figures as the above rating is 10% less than actual results obtained by the ARI principles.

2.2 FEATURES:

- 2.2.1 Designed with the highest quality components and manufactured in an ISO-9001 Registered facility.
- 2.2.2 The JAVAC Xtract-R Refrigerant Recovery Machine utilises a new oil-less compressor technology that is highly tolerant of liquid and is easier to maintain since it has no Inlet Valve. The compressor also handles high inlet and discharge pressure starting.
- 2.2.3 Easy to use with simplified valve settings for operation.
- 2.2.4 Inlet (Suction) and Discharge pressure gauges allow the process to be monitored from start to finish.
- 2.2.5 The unit's lightweight and excellent balance makes it easy to transport to the job site and into difficult locations. The handle is easy to grasp and the unit is exceptionally well balanced - the carry strap enhances the portability of the unit.
- 2.2.6 The PURGE operation can be accomplished without changing hoses.
- 2.2.7 The high impact moulded case resists damage and is designed to protect the gauges, valve knobs and hose connection ports from incidental damage caused during operation, handling and storage.
- 2.2.8 Should damage occur to the gauges they can be replaced in minutes.

2.3 WARRANTY:



- 2.3.1 JAVAC warrants your Xtract-R Refrigerant Recovery Machine to be free from defects of materials or workmanship for one year from the date of purchase. JAVAC does not warrant any machine that has been subjected to misuse, negligence, or accident, or has been repaired or altered by anyone other than JAVAC.
- 2.3.2 The manufacturer warrants the Compressor for a period of one year. To keep this WARRANTY in force it is required that a standard filter or filter drier be used on the Inlet Port or Hose at all times to prevent particulate from entering the compressor. FAILURE TO USE A FILTER WILL VOID THE COMPRESSOR WARRANTY.
- 2.3.3 JAVAC's liability is limited to machines returned to the place of purchase, transportation prepaid, not later than thirty (30) days after the warranty period expires, and which JAVAC judges to have malfunctioned because of defective materials or workmanship. JAVAC's liability is limited to, at its option, repairing or replacing the defective machine or part.

2.3.4 This WARRANTY is in lieu of all other warranties, express or implied, whether of MERCHANTABILITY or of FITNESS FOR A PARTICULAR PURPOSE or otherwise. All such other warranties are expressly disclaimed.

2.3.5 JAVAC shall have no liability in excess of the price paid to JAVAC for the machine plus return transportation charges prepaid. JAVAC shall have no liability for any incidental or consequential damages. All such liabilities are EXCLUDED.

3.0 SETUP AND OPERATION:

3.1 GETTING STARTED:

- 3.1.1  **CAUTION:** Only personnel who have been properly trained in the use and operation of Refrigeration Systems, Refrigerants and Service Equipment should operate this equipment. **Failure to follow proper safety precautions could result in personal injury or death.**
- 3.1.2  **CAUTION:** Review the full contents of this Manual before attempting to use the Xtract-R in actual service.
- 3.1.3 Identify the refrigerant to be recovered and prepare the Xtract-R for use by installing an approved filter and hoses. Refer to Section 4.0 of this Manual for approved accessories.
- 3.1.4 Connect the Mains Power cord to a circuit that is protected by a 10 amp breaker. Use an extension cord only when absolutely necessary to perform the service; be sure it is the minimum length required, that it contains a safety ground wire and that it contains wires sized 16 AWG (1.291 MM) or larger.
- 3.1.5 Make sure the Xtract-R is set in a stable position and that it is reasonably level; observe all safety precautions previously noted. Ensure that the fan inlet and discharge areas on both sides of the machine are clear from obstructions.
- 3.1.6 Check all connections to ensure they are tight before starting the Recovery Operation.
- 3.1.7 When recovering refrigerant it may be necessary to throttle the Manifold Gauge control valve(s) or the Xtract-R's INLET Valve when a significant amount of liquid is present. This is required if a loud "knocking" sound is

heard from the compressor. While the Compressor in the Xtract-R is tolerant of liquid, no compressor will run on 100% liquid without damage for more than a few minutes. In addition, a liquid “slug” can cause the high-pressure shutoff to activate, thus adding time to the process. It is thus important to open the valves slowly and monitor the process carefully. Should the compressor start to “Knock”, rotate the INLET valve clockwise until the “knocking” stops. This can also be accomplished by adjusting the Manifold Gauge valves. Exercise care to ensure that the compressor is not damaged in this way as it will void the warranty.



- 3.1.8 Use a Refrigerant Scale to ensure that the cylinder is not filled to more than 80% of its capacity by weight. When operating in the NORMAL RECOVERY or PUSH-PULL mode it is possible to overfill the cylinder. Check the cylinder weight before transporting if you are not sure. Refer to Section 8.0 of this Manual. **OVERFILLED CYLINDERS CAN RUPTURE EXPLOSIVELY!**

3.2 NORMAL RECOVERY OPERATION

- 3.2.1 Connect all cables and hoses as described in Section 3.1 above and as shown in the diagram below. Ensure that they are tight and routed in such a way that they will not interfere with the operation.

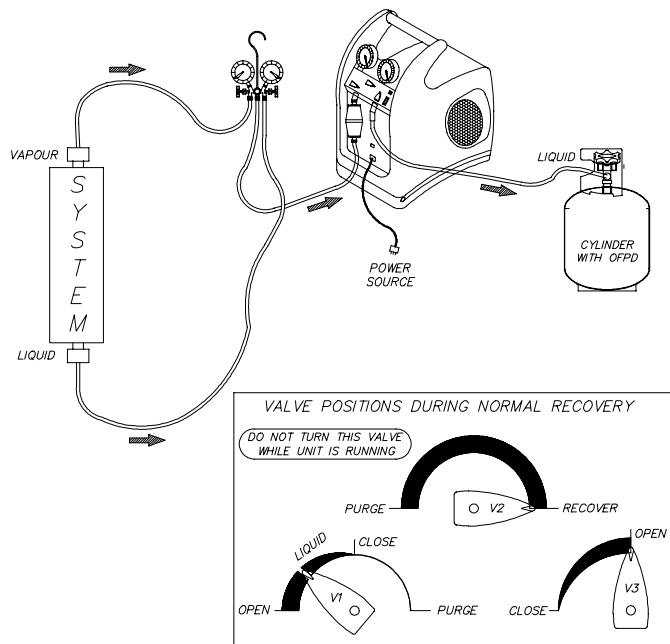

SET-UP PROCEDURE FOR NORMAL REFRIGERANT RECOVERY

- 3.2.2 Switch off the power to the unit being serviced. If the power switch is in a remote location, LOCK it out so that no one will accidentally turn it back on.
- 3.2.3 Make sure that the hose from the Xtract-R to the Recovery Cylinder is attached to the LIQUID PORT. Open the cylinder's LIQUID PORT valve, keeping the VAPOR port closed.
- 3.2.4 Set the Xtract-R for RECOVERY.
 - 3.2.4.1 OPEN the DISCHARGE valve (V3) to its fully open position.
 - 3.2.4.2 SET the PURGE/RECOVERY valve (V2) to the RECOVERY position.
- 3.2.5 Open the Manifold Gauge LIQUID valve slowly and verify that no leaks are present. Extracting as much liquid as possible will speed up the recovery process.
- 3.2.6 Switch ON the Xtract-R and verify that the cooling fan and compressor are operating.
- 3.2.7 MONITOR the inlet pressure (LP, Low Pressure Gauge) and SLOWLY OPEN the Xtract-R's INLET valve (V1). THROTTLE the INLET valve or the Manifold Gauge's Liquid and Vapour valves if too much liquid is entering the machine. Refer to Para. 3.1.7, above.
- 3.2.8 When the liquid has been transferred, OPEN the INLET valve (V1) fully to transfer the remaining VAPOR. Ensure that the Manifold Gauge valves (liquid and vapour) are also fully opened.
- 3.2.9 Continue to operate until the required VACUUM has been pulled on the system (refer to Section 8.0 of this Manual), as indicated by the LP gauge. Switch OFF the Xtract-R , CLOSE the INLET (V1), and wait for 5 minutes. If the Pressure in the system, as noted on the Manifold Gauge, rises above 0 Kpa, refrigerant is still present. If this is the case, REOPEN the INLET (V1), RESTART the Xtract-R , and run until the required VACUUM is reached again. Repeat this process until all the refrigerant is removed resulting in a final reading, after the 5 minute period, of 0 Kpa or less.
- 3.2.10 TERMINATE the RECOVERY operation.
 - 3.2.10.1 CLOSE the Manifold Gauge Liquid and Vapour valves.
 - 3.2.10.2 CLOSE the Xtract-R's INLET Valve (V1).
 - 3.2.10.3 Switch the POWER OFF on the Xtract-R.

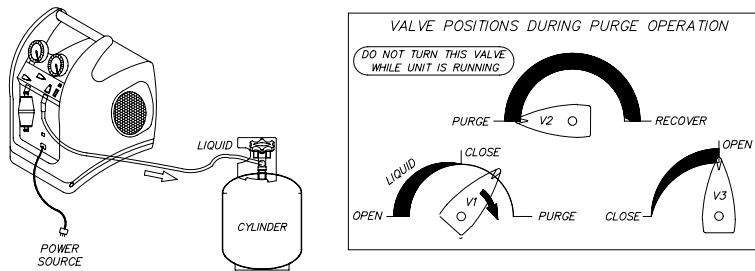

3.2.10.4 IMMEDIATELY PURGE the Xtract-R per the procedure as described in Section 3.3 of this Manual.

3.3 PURGING the Xtract-R

- 3.3.1 Rotate the INLET Valve (V1) to the CLOSED position and ensure that the **POWER is switched OFF**.
- 3.3.2 Rotate the PURGE/RECOVERY valve (V2) to the PURGE position.
- 3.3.3 Switch the **POWER ON** and rotate the INLET valve (V1) slowly to the PURGE position to avoid flooding the compressor with liquid. The compressor will now start.
- 3.3.4 Observe the LP Gauge and continue to run the unit until a VACUUM of at least 600mm Hg is achieved. When the proper Vacuum has been achieved, switch the POWER OFF and immediately CLOSE the Recovery Cylinder's valve. The INLET valve (V1) should be left in the PURGE position. Finally close V3.
- 3.3.4 IMPORTANT - RETURN V2 TO RECOVERY POSITION



- 3.3.6 **CAUTION** - THE HOSE AND THE DISCHARGE PORT WILL CONTAIN A SMALL AMOUNT OF REFRIGERANT UNDER PRESSURE. EXERCISE CARE WHEN REMOVING THIS HOSE AND OPENING THE VALVE V3.
- 3.3.7 REMOVE all hoses and cables and prepare the machine and the recovery cylinder for transport.
- 3.3.8 When changing refrigerants or reconnecting to a cylinder always purge the hoses and the Xtract-R ports with refrigerant, (or evacuate lines), to prevent air entering the recovery process.

3.4 PUSH PULL OPERATION

- 3.4.1 The PUSH PULL method is used to move a large amount of liquid refrigerant from the system being serviced to the recovery cylinder without passing it through the compressor. This method is only useful when more than 7 kg of liquid is known to be in the system and it can be easily isolated. DO NOT ATTEMPT the PUSH PULL process unless you are sure of the situation.
- 3.4.2 Connect the refrigerant hoses as shown below. The addition of a SIGHT GLASS in the line from the system being serviced to the recovery cylinder is an important aid to determine when the liquid has been transferred and vapour remains.
- 3.4.3 This process uses the PULL from the exhausted recovery cylinder and the Discharge PUSH from the Xtract-R to move the liquid refrigerant. Rates in excess of 5 kg per minute can be achieved by this procedure.
- 3.4.4 The SCALE is required in this process to ensure that the cylinder is not overfilled. The cylinder shutoff switch, if used, would stop the compressor but could not guarantee that additional refrigerant flow would cease because of the dynamics of the system, thus possibly overfilling the cylinder.

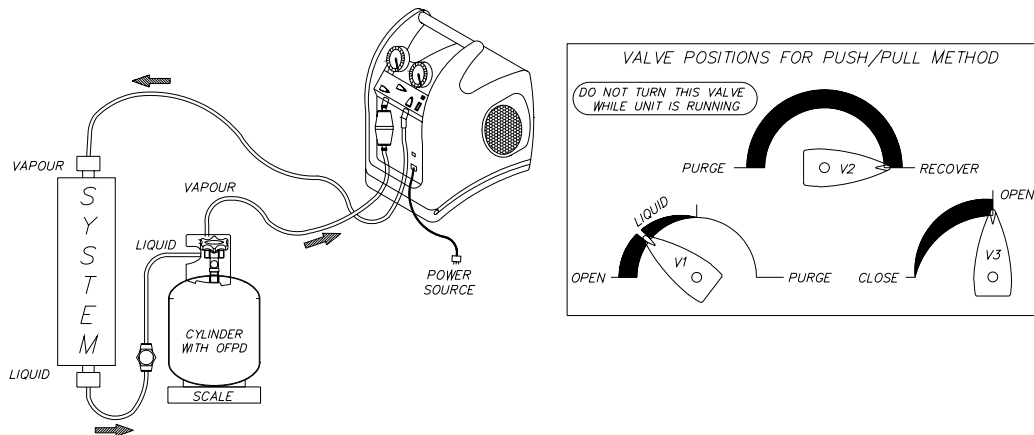

SET-UP PROCEDURE FOR PUSH-PULL METHOD

3.5 COOLING THE RECOVERY CYLINDER

- 3.5.1 The Xtract-R can be used to PRE-cool (or SUB-cool) the recovery cylinder if the head pressure is too high to complete the recovery process. This can occur when working with certain refrigerants with a high vapour pressure when the ambient temperature is high.
- 3.5.2 If the recovery process stalls out because of high head pressure, stop the Xtract-R, shut off the hose valves and reconfigure the set-up as shown below. This can also be done before starting the recovery process but it may have marginal long-term effect. NOTE: This will only work if there is at least 5 kg of liquid in the recovery cylinder to develop the necessary pressure differential required.
- 3.5.3 POWER ON the Xtract-R and ROTATE the DISCHARGE Valve (V3) to achieve a pressure differential of at least 700 Kpa between the LP Gauge and the HP Gauge. KEEP THE HP BELOW 2500 Kpa on the HP Gauge to ensure that the HP cut-off Switch will not actuate.
- 3.5.4 After several minutes of running, the cylinder will be cold. POWER OFF the Xtract-R and reconfigure the set-up for NORMAL RECOVERY. Repeat as needed.

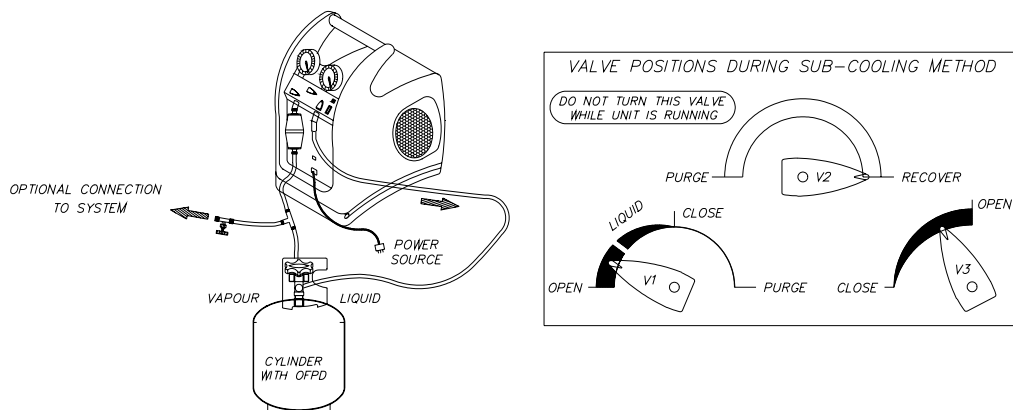

SET-UP PROCEDURE FOR SUB-COOLING METHOD

3.6 SPECIAL OPERATING NOTES

- 3.6.1 During normal operation, when the High Pressure switch activates, the

machine will restart automatically when the head pressure drops below approximately 2500 Kpa.

- 3.6.2 When the optional Pressure Control Circuit is installed and the High-Pressure switch activates, the machine must be cycled OFF and back ON for the compressor to restart. The “High Pressure Cut Out” signal light (red) on the PCC plate will be illuminated when this is the case.
- 3.6.3 When the optional Pressure Control Circuit, is equipt with the Over Fill Protection Device and the OFPD cable is not connected, or when the cylinder is full, the yellow “Cylinder Full” signal light will be illuminated. When this is the case, the compressor will start briefly if the Power is cycled OFF and back ON, but it will not run more than a few seconds. This is normal operation.

3.7 STORAGE

- 3.7.1 When the recovery process has been completed, carefully coil the Power Cord, the Refrigerant Hoses and the Cylinder Overfill Protection Cord (if used), ensuring that no dirt or foreign material is left in the ends or on the connectors.
- 3.7.2 Place the Xtract-R in the service vehicle in its upright position and store the hoses and cords nearby. Provide reasonable care to place the unit where it will not be subjected to accidental damage due to shifting items during transit or to heavier objects being placed on its top.
- 3.7.3 The unit can be stored safely in temperatures of 0⁰ - 50⁰ C and humidity levels up to 95% RH. When stored in conditions that are severe, the unit may need to stabilise in the range 10⁰ - 40⁰C before it will offer optimum operating performance. For best results, store the unit in an environmentally controlled area when not in use.
- 3.7.4 Always purge and vent the Xtract-R prior to storage, close V1 & V3 and leave V2 in the Recover Position

4.0 APPROVED ACCESSORY ITEMS

- 4.1 The Xtract-R Refrigerant Recovery Machine requires the proper accessory items to ensure the best performance. The following items are specifically identified to ensure safety and operational requirements are met. Check with your Wholesaler to ensure that the proper selections have been made.
 - 4.1.1 REFRIGERANT HOSES should be made with approved materials, should be as short as possible to perform the required operations and should have shut-off devices within 300mm of the ends.

- 4.1.2 RECOVERY CYLINDERS should be approved and have an appropriate pressure rating for the refrigerant being recovered. Choose the size (normally 20 or 60 Kg) that is right for the job.
- 4.1.3 FILTERS should be selected to protect the Inlet of the Xtract-R from particles of dust, metal and other foreign materials that may be present in the refrigeration system. If servicing a system with a burned out compressor, 2 or more FILTERS in series may be necessary, and they should be discarded immediately after use.
- 4.1.4 EXTENSION CORDS, when necessary, should be as short as possible and should contain size 16 AWG (1.291 MM) or larger conductors. This is necessary to avoid overheating during periods of high current draw and minimise the risk of fire. The longer the extension cord required at the work site, the larger the conductor size should be particularly for runs over 10m.
- 4.1.5 PRESSURE CONTROL CIRCUIT - OVER FILL DEVICE, the Javac Xtract-R has been designed to be user upgraded to incorporate an integrated Pressure Control Circuit. The PCC upgrades the machine to a latching High-Pressure switch, (as opposed to automatic). Allows provision for an optional factory fitted Low Pressure switch, (requires switch, loom and plumbing changes), plus an optional low voltage input, (requires socket and cable), which, where fitted can be used to connect to cylinders which incorporate floats, cylinder scales or timers etc. Note: Because not all cylinders are available with Brad Harrison 3 pin connectors the facility will vary depending upon the market.

5.0 MAINTENANCE

- 5.1 Your Xtract-R will provide many seasons of reliable service providing it is properly maintained. The actual maintenance requirements are minimal but important.
- 5.2 Keep the unit clean by wiping it down with a damp cloth to remove dirt, oils, etc. prior to storage for the day. Standard household detergent or isopropyl alcohol may be used if the unit is particularly dirty; in all cases, exercise care to prevent liquids from entering the unit. Gasoline and other solvents are to be avoided as they can damage the Xtract-R's plastic enclosure and they are hazardous.
- 5.3 Ensure that the Inlet and Discharge ports are protected in transit and storage; keep the inner diameter and the outer threads clear and clean. For best results, keep a FILTER permanently connected to the INLET port and change it regularly.

- 5.4 Change HOSES periodically as they develop leaks and a build-up of contaminants over time. Change hoses at least once per season.
- 5.5 When storing the Xtract-R for the season, or for long periods of time, PURGE the unit with an inert gas such as Nitrogen.
- 5.6 When performance falls off it is likely that the compressor seals require replacing. This is normal with use and may occur after a year or two or more often, depending upon the conditions that are prevalent during the recovery operations. Contact your Wholesaler for assistance in selecting the proper maintenance kit.

6.0 TROUBLESHOOTING

PROBLEM	CAUSE	ACTION
Unit will not start - Fan does not run; compressor does not start; no light in Power Switch	<ul style="list-style-type: none"> • Power Cord not attached • No voltage at receptacle 	<ul style="list-style-type: none"> • Attach Power Cord • Verify voltage at Job Site

Cooling fan runs but compressor will not start	<ul style="list-style-type: none"> • Circuit breaker has opened • Discharge pressure too high • HP Switch has opened • Insufficient pressure to close LP switch. • Electronics failure in Motor, Bridge Rectifier or Filter Capacitor 	<ul style="list-style-type: none"> • Identify cause of breaker activation, rectify and reset • Reduce pressure and rotate V2 to Purge and back to Recovery • Reduce pressure • Factory service required • Check connection, hoses, valves, gauges, system may not contain refrigerant
Compressor runs but cooling fan will not start	<ul style="list-style-type: none"> • Thermal cut-out has opened in fan motor 	<ul style="list-style-type: none"> • One time switch - fan motor must be replaced - factory service required
Compressor starts but cuts out within a few minutes; pressure indication on HP gauge is high	<ul style="list-style-type: none"> • V2 is in Purge position and HP switch activates • V3 not open and HP switch activates • Recovery cylinder valve not open • Blocked discharge hose • Air in system/cylinder 	<ul style="list-style-type: none"> • Rotate V2 to Recovery • Rotate V3 to open position • Open cylinder valve • Check & clear blockage • Bleed air from system/cylinder
Compressor stops intermittently	<ul style="list-style-type: none"> • Vapour pressure of refrigerant in cylinder is close to HP trip point 	<ul style="list-style-type: none"> • Reduce cylinder temperature
Unit overheats	<p>Excessive head pressure due to:</p> <ul style="list-style-type: none"> • High ambient temperature • Restricted discharge hose • Air in recovery cylinder 	<ul style="list-style-type: none"> • Reduce cylinder temperature • Check & clear restriction • Bleed air from cylinder
Recovery process too slow	<ul style="list-style-type: none"> • Head pressure too high • System refrigerant iced up • Compressor seals are worn 	<ul style="list-style-type: none"> • Reduce cylinder temperature or change cylinders • Throttle gauge manifold valves and V3 to reduce pressure differential between LP and HP gauges • Interrupt process to allow ice to dissipate • Rebuild compressor with service kit - check with wholesaler for assistance

7.0 SERVICE - CONSTRUCTION AND SCHEMATIC

7.1 SERVICE

7.1.1 The Xtract-R uses only UL or CSA or TUV Recognised electrical components or components which have been specially designed for this application.

7.1.2  DO NOT CHANGE any of these components as the safety of the machine could be compromised. All service work must be performed at an JAVAC approved facility in order to maintain the safety rating and the Warranty, if applicable.

- 7.1.3 Technical assistance and service information can be obtained by contacting the organisation where you purchased the recovery machine.

NOTE: Do not return a defective unit directly to the factory.
Contact your Wholesaler for assistance.

- 7.1.4 The following Parts and Accessories for your Xtract-R are available through the same dealer from whom you purchased the unit, for electrical parts see 7.3 below :

Xtract-R EMRT-2	PART #
Strap, shoulder, 15Kg cap. 50mm wide 1600 long, adj.swiv. clips	QD52550
Instuction booklet Xtract-R Australia UK version	QD52568
Cap and strap, plastic with lead, 7/16.20 suit 1/4 M SAE	QC20015
Handle, aluminium tube	QD52553
Condenser (2 row, 8" x 7", 3/8 tube, ¼ tube ends, 1/4" fl nuts)	QD52528
Cord set (IEC to Australian/ NZ plugtop, 240V 10A)	D20808
Cord set (IEC to UK plugtop 240V 10A)	1111
Manifold Assembly Complete (including pressure switch)	QA21002
Manifold Knob Set (3)	QS22014
Manifold service Kit	QS22020
Gauge, High Pressure Javac (1/8 NPT M Conns.)	D21605
Gauge, Low Pressure Javac (1/8 NPT M Conns.)	D21603
Case Housing - Fan Mount	QD52535
Case Housing - Condenser Mount	QD52536
Foot, rubber reinforced (bore Dia 4mm, OD 22 x 8 high HH757 X 20)	QC20025
Xtract-R EMRT-21	
Pressure Control Circuit Board (with cover plate – label no connector)	QA21007
Connector socket for Overfill cable (Optional)	QC20068
Overfill cable yellow (Optional) Brad harrison 3 pin conector	QC20032

- 7.1.5  Only technically qualified personnel who are familiar with basic electronics and refrigeration systems should install the Pressure Control Circuit. Disassembly of the unit to rebuild the compressor or to provide other repair work should be referred to an approved service center as indicated above.

7.2 CONSTRUCTION

- 7.2.1 The JAVAC Xtract-R is constructed from the highest-grade materials to exacting standards. All assembly and testing is performed in an ISO-9001 Registered facility.

- 7.2.2 This unit is manufactured with environmentally compatible components, which can be substantially recycled at the end of the product's useful life. Consult your local agencies for proper recycling.
- 7.2.3 The Xtract-R contains no hazardous materials.

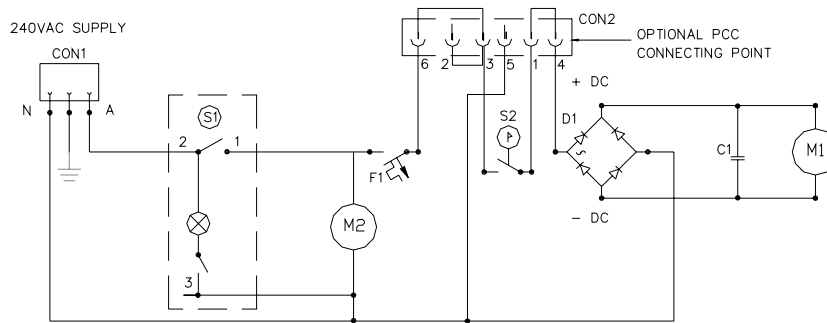

7.3 ELECTRICAL SCHEMATIC

ELECTRICAL SCHEMATIC DIAGRAM

ITEM	DESCRIPTION	PART NO.	QTY.
M1	COMPRESSOR , 500CDR75 230 V 50 Hz	QC20049	1
M2	FAN MOTOR, SHADED POLE 0.9A, 230V, 50 Hz (complete assembly)	QA21029	1
C1	CAPACITOR, 470mfd, 400VDC	QC20039	1
D1	RECTIFIER, SILICON BRIDGE TYPE 25A, 600V	QC20001	1
S1	SWITCH, ROCKER ILLUM, 20A, 125/220V, SPST green	QC20005	1
S2	PRESSURE SWITCH, C0450C1358	QC20011	1
CON1	IEC SOCKET, MALE -FILTER, 15A, 250V	QC20062	1
CON2	LOOM - PLUG & SOCKET HOUSING 600V, 20A & WIRES 16 AWG, 26/30 105° C, 300V – Australian / UK version.	QD52557	1
F1	CIRCUIT BREAKER, 7A, 125/250V	QC20050	1

ELECTRICAL PARTS - SPARE/PARTS LIST

8.0 RECOVERY CYLINDER SAFETY

- 8.0.1 Recovery Cylinders are tested to specific requirements to ensure that they will be safe during the transportation process. These requirements ensure the safety of the cylinder when it is filled to an appropriate level and when it is exposed to elevated temperatures, as in a truck or on a hot day outside.

- 8.0.2 However, a cylinder that is overfilled may still be unsafe, even though the rating is acceptable for the particular refrigerant. It is therefore extremely important, as noted in Sections 1 and 3 of this Manual, to ensure that the cylinder is not overfilled.



- 8.2.4 The cylinder must not be filled beyond 80% of its capacity. If a scale is to be used, this weight can be determined by taking 80% of the Water Capacity (WC) weight that is marked on the cylinder and adding that to the Tare Weight (TW) of the cylinder. The TW is also marked on the cylinder.

- 8.2.5 If the cylinder is partially filled and the TW is unknown, then you may use the following chart as a guideline. **MAXIMUM TOTAL** weights should be used for the recovery process using the weigh scale:

CYLINDER SIZE (WATER CAPACITY)	NET REFRIGERANT WEIGHT	MAXIMUM TOTAL WEIGHT (APPROX.)
13.64 kg	10.91 kg	17..27 kg
22.73 kg	18.18 kg	26.81 kg
43.18 kg	34.54 kg	53.63 kg
65.91 kg	44.54 kg	69.54 kg
108.81 kg	86.36 kg	124.54 kg