

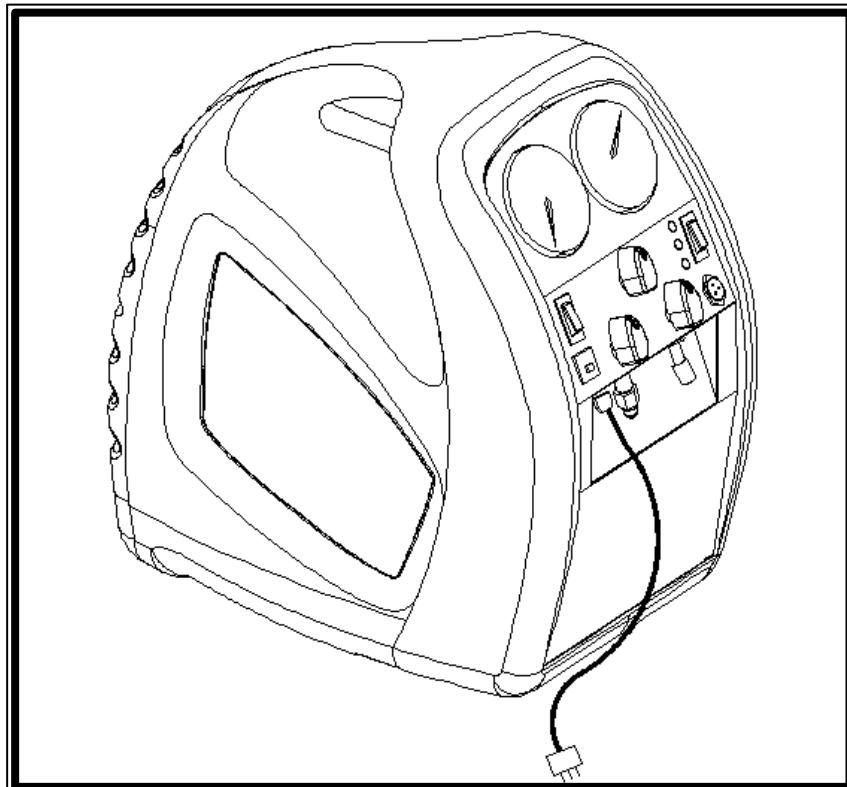

JAVAC Pty Ltd

EVO-HS
REFRIGERANT RECOVERY MACHINE

User Manual



EVO-HS combines an innovative refrigerant gas compression system with a rugged, moulded case that is designed to offer maximum protection from damage during transit and normal handling. With normal use and with care as prescribed in this Manual, your EVO-HS will give you years of trouble-free operation.

Safety First!



When found on the machine, this international symbol is intended to alert the user to the presence of important operating, safety and maintenance (servicing) instructions in this Manual. As used in the Manual, it is intended to draw your attention to critical items.

It is Thank you for purchasing the Javac EVO-HS Refrigerant Recovery Machine!

important to read this entire Manual and be familiar with its contents before using the machine!

The EVO-HS is a Recovery Machine suitable only for R134a. Recovering refrigerants into a separate storage cylinder involves a process of gas compression, resulting in high pressures within the machine, the connecting hoses and the storage cylinder. High-pressure systems must always be treated with care and respect to prevent careless accidents.

Responsibility:





A Qualified Technician who has been properly trained in the care and use of such equipment and in the recovery process itself must only operate the Javac EVO-HS. Use of this equipment by unqualified personnel is potentially dangerous and should not be attempted.

TABLE OF CONTENTS

SECTION AND DESCRIPTION:

- 1.0 SAFETY PRECAUTIONS**
- 2.0 SPECIFICATIONS, FEATURES AND WARRANTY**
- 3.0 SET UP AND OPERATION**
 - 3.1 GETTING STARTED**
 - 3.2 NORMAL RECOVERY OPERATION**
 - 3.3 PURGING THE EVO-HS**
 - 3.4 COOLING THE RECOVERY CYLINDER**
 - 3.5 SPECIAL OPERATING NOTES**
 - 3.6 STORAGE**
- 4.0 APPROVED ACCESSORY ITEMS**
- 5.0 MAINTENANCE**
- 6.0 TROUBLESHOOTING**
- 7.0 SERVICE - CONSTRUCTION AND SCHEMATIC**
- 8.0 RECOVERY CYLINDER SAFETY**

1.0 SAFETY PRECAUTIONS:

- 1.11  **DISCONNECT POWER** before moving or servicing the Javac EVO-HS **CAUTION** - this unit should be opened only by a technically qualified person who has been trained in basic electronics and refrigeration. The risk of **ELECTRIC SHOCK** and exposure to **HOT** compressor parts is possible if the unit is opened.
- 1.12  **WARNING - TO REDUCE THE RISK OF FIRE, EXTENSION CORDS SHOULD NOT BE USED** with this equipment as the wiring can overheat under conditions of high current draw. If an extension cord is absolutely necessary, its length should be as short as possible and it should contain size 16 AWG (1.291 mm) or larger wiring.
- 1.13  **FLAMMABLE ENVIRONMENTS ARE DANGEROUS** when any machine is used because motors and switches can generate sparks. This equipment should be used in locations with mechanical ventilation providing at least four air changes per hour, or the equipment should be located at least 18” above the floor. **DO NOT USE THIS EQUIPMENT IN THE VICINITY OF SPILLED OR OPEN CONTAINERS OF GASOLINE OR ANY OTHER FLAMMABLE LIQUID.**
- 1.14 **MOISTURE** can cause severe damage when introduced to the internal parts of a refrigeration system. Ensure that care is exercised in the leak detection, recovery, repair and refilling of a system to prevent moisture from entering. Always use a quality high vacuum pump such as Javac Shark/Deluxe to ensure the system is totally dehydrated. An electronic total pressure gauge such as the Acravac should also be used to monitor the pressure.
- 1.15  **USE CAUTION WHEN OPERATING OUTDOORS.** Be certain that the power cord, the cylinder safety cord and the unit itself are not placed in water or other potentially dangerous locations. While the EVO-HS is very safe to operate, using in environments such as hard rain or sand dust storms should be avoided.
- 1.16  **CAUTION - EXERCISE CARE WHEN MOVING** the equipment to prevent the risk of injury.

2.0 SPECIFICATIONS, FEATURES AND WARRANTY

2.1 EVO-HS SPECIFICATIONS:

- 2.1.1 Refrigerants: For refrigerant 134a
- 2.1.2 Power: 220/240 VAC, 50 Hz, 1.5A
- 2.1.3 Compressor: Hermetic
- 2.1.4 Cooling: Electric Fan
- 2.1.5 Protection: High Pressure Switch Cut off at 1900 kPa
- 2.1.6 Pressure: Low side design pressure 1600 kPa;
High side design pressure 3200 kPa
- 2.1.7 Temperature: Operating Range 10⁰ to 40⁰ C
- 2.1.8 Case: Blow-Moulded, High Impact Strength
- 2.1.9 Size: 390mm L X 250mm W X 380mm H
- 2.1.10 Weight: 12.8 Kg

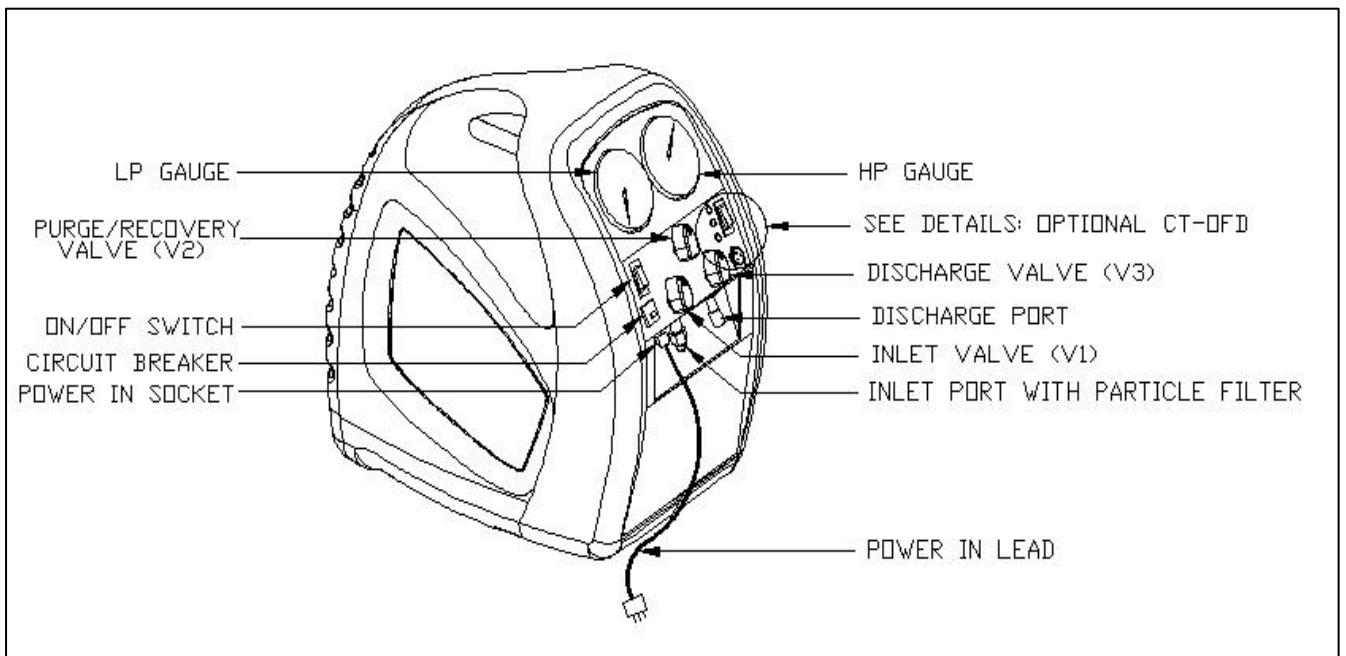

2.2 FEATURES:

- 2.2.1 Designed with the highest quality components and manufactured in an ISO-9001 Registered facility.
- 2.2.2 Factory fitted with an inlet particle filter, which traps contaminants. This filter is easy to remove, clean or replace in the event of restricted flow.
- 2.2.3 Inlet (Suction) and Discharge pressure gauges allow the process to be monitored from start to finish.
- 2.2.4 The unit's lightweight and excellent balance makes it easy to transport to the job site and into difficult locations. The handle is easy to grasp and the unit is exceptionally well balanced.
- 2.2.5 The PURGE operation can be accomplished without changing hoses.
- 2.2.6 The high impact moulded case resists damage and is designed to protect the gauges, valve knobs and hose connection ports from incidental damage caused during operation, handling and storage.



2.3 WARRANTY:

- 2.3.1 Javac warrants your EVO-HS Refrigerant Recovery Machine to be free from defects of materials or workmanship for two years from the date of purchase. Javac does not warrant any machine that has been subjected to misuse, negligence, or accident, or has been repaired or altered by anyone other than Javac. The EVO-HS is designed and manufactured as a general recovery machine for intermittent operation. For instances in commercial applications involving high duty cycles or continuous running the EVO-HS is warranted for a period of 3 months from the date of purchase.
- 2.3.2 The manufacturer warrants the Compressor for a period of one year. To keep this WARRANTY in force it is required that the standard filter and a filter drier be used on the Inlet Port or Hose at all times to prevent particulates from entering the compressor. **FAILURE TO USE A FILTER WILL VOID THE COMPRESSOR WARRANTY.**
- 2.3.3 Failure to maintain correct oil level in the compressor will void compressor warranty.
- 2.3.4 Javac's liability is limited to machines returned to Javac, return transportation prepaid, not later than thirty (30) days after the warranty period expires, and which Javac judges to have malfunctioned because of defective materials or workmanship. Javac's liability is limited to, at its option, repairing or replacing the defective machine or part.

- 2.3.5 This WARRANTY is in lieu of all other warranties, express or implied, whether of MERCHANTABILITY or of FITNESS FOR A PARTICULAR PURPOSE or otherwise. All such other warranties are expressly disclaimed.
- 2.3.6 Javac shall have no liability in excess of the price paid to Javac for the machine plus return transportation charges prepaid. Javac shall have no liability for any incidental or consequential damages. All such liabilities are EXCLUDED.

3.0 SETUP AND OPERATION:

3.1 GETTING STARTED:

- 3.1.1  **CAUTION:** Only personnel who have been properly trained in the use and operation of Refrigeration Systems, Refrigerants and Service Equipment should operate this equipment. **Failure to follow proper safety precautions could result in personal injury or death.**
- 3.1.2  **CAUTION:** Review the full contents of this Manual before attempting to use the EVO-HS in actual service.
- 3.1.3 Identify the refrigerant to be recovered and prepare the EVO-HS for use by installing an approved filter, hoses and optional shutoff cable or scale per the diagram below. Refer to Section 4.0 of this Manual for approved accessories.
- 3.1.4 Connect the AC Power cord to a circuit that is protected by a 4 amp breaker. Use an extension cord only when absolutely necessary to perform the service; be sure it is the minimum length required, that it contains a safety ground wire and that it contains wires sized 16 AWG (1.291 mm) or larger.
- 3.1.5 Make sure the EVO-HS is set in a stable position and that it is reasonably level; observe all safety precautions previously noted. Ensure that the fan inlet and discharge areas on both sides of the machine are clear from obstructions.
- 3.1.6 Check all connections to ensure they are tight before starting the Recovery Operation.
- 3.1.7 EVO-HS is a liquid tolerant recovery machine. **It is important to remember to START the machine before opening the INLET valve.** Should the compressor start to 'Knock', close the INLET valve immediately and while it is still running, slowly open the valve back again.

- 3.1.8  Use a Refrigerant Scale to ensure that the cylinder is not filled to more than 80% of its capacity by weight. When operating in the NORMAL RECOVERY mode without the cylinder shutoff it is possible to overfill the cylinder. If you are not sure check the cylinder weight before transporting. Refer to Section 8.0 of this Manual. **OVERFILLED CYLINDERS CAN RUPTURE EXPLOSIVELY!**

3.2 NORMAL RECOVERY OPERATION

- 3.2.1 Connect all cables and hoses as described in Section 3.1 above and as shown in the diagram below. Ensure that they are tight and routed in such a way that they will not interfere with the operation.

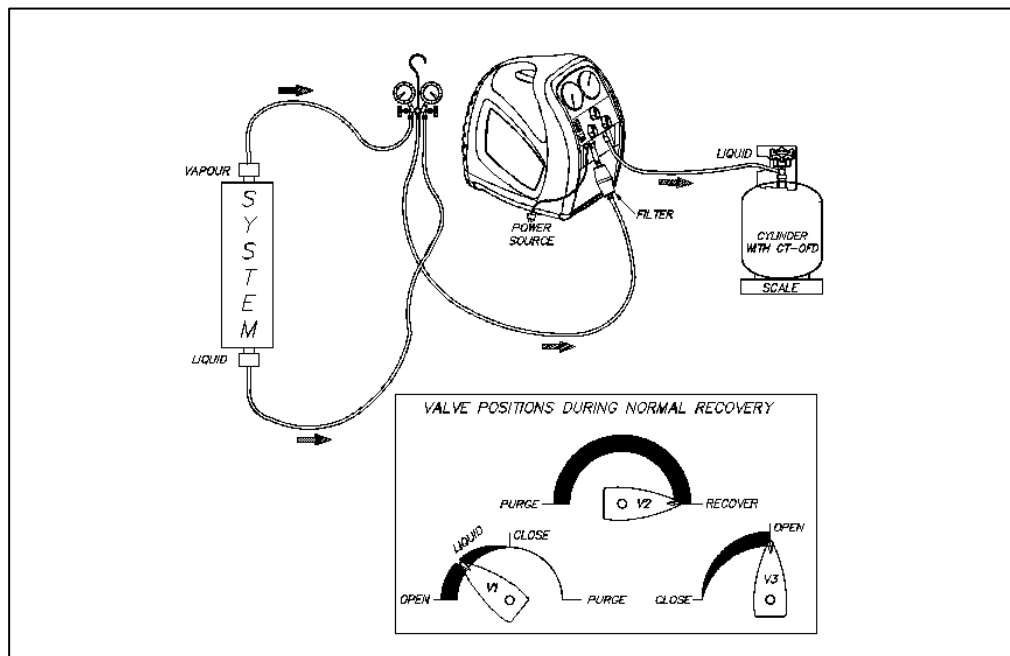

SET-UP PROCEDURE FOR NORMAL REFRIGERANT RECOVERY

- 3.2.2 Switch off the power to the unit being serviced. If the power switch is in a remote location, LOCK it out so that no one will accidentally turn it back on.
- 3.2.3 Make sure that the discharge hose from the EVO-HS to the Recovery Cylinder is attached to the LIQUID PORT. If cylinder contains refrigerant, partially open liquid valve and purge hose from EVO-HS discharge port end. If cylinder is empty and pre – evacuated, refer to section 3.2.4.4 and use incoming refrigerant to purge discharge hose from cylinder port end. Open cylinder liquid valve fully after purging hose.
- 3.2.4 Set the EVO-HS for RECOVERY.

- 3.2.4.1 OPEN DISCHARGE valve (V3) to its fully open position.
- 3.2.4.2 SET PURGE/RECOVERY valve (V2) to RECOVERY position.
- 3.2.4.3 Open the Manifold Gauge VAPOUR valve slowly and verify that no leaks are present. Open vapour valve fully and partially open liquid valve. Do not attempt to recover 100% liquid
- 3.2.4.4 At this point use incoming refrigerant to purge hose.
- 3.2.5 Switch ON the EVO-HS and verify that the compressor is operating and cooling air is exhausting from the back of the machine.
- 3.2.6 MONITOR the inlet pressure (LP, Low Pressure Gauge) and SLOWLY OPEN the EVO-HS's INLET valve (V1) fully. If the compressor 'knocks' shut V1 immediately, then close manifold liquid valve. Open V1 while the machine is running and continue to recover in vapour phase.
- 3.2.7 Continue to operate until the required VACUUM has been pulled on the system (refer to Section 8.0 of this Manual), as indicated by the LP gauge. Switch OFF the EVO-HS, CLOSE the INLET (V1), and wait for 5 minutes. If the Pressure in the system, as indicated on the Manifold Gauge, rises above 0 Kpa, refrigerant is still present. If so, RESTART EVO-HS, REOPEN the INLET (V1) and run until the required VACUUM is reached again. Repeat this process until all the refrigerant is removed resulting in a final reading of 0 Kpa or less.
- 3.2.8 TERMINATE the RECOVERY operation.
 - 3.2.8.1 CLOSE Manifold Gauge Liquid and Vapor valves.
 - 3.2.8.2 CLOSE EVO-HS's INLET Valve (V1).
 - 3.2.8.3 Switch POWER OFF on the EVO-HS.
 - 3.2.8.4 It is a good practice to purge the EVO-HS after each use. Refer to section 3.3 of this manual.

3.3 PURGING the EVO-HS

- 3.3.1 While EVO-HS is running rotate INLET Valve (V1) to CLOSE position.
- 3.3.2 Rotate PURGE/RECOVERY valve (V2) to PURGE position. Leave DISCHARGE (V3) open.
- 3.3.3 Slowly rotate Inlet V1 to PURGE position.

3.3.4 Observe LP Gauge and continue to run the unit until a VACUUM is achieved. Switch POWER OFF and CLOSE the Recovery Cylinder valve. Return INLET valve (V1) CLOSE position and close V3.

3.3.5 IMPORTANT – Return V2 to RECOVERY Position

3.3.6  **CAUTION** - THE DISCHARGE PORT AND HOSE WILL CONTAIN A SMALL AMOUNT OF REFRIGERANT UNDER PRESSURE. EXERCISE CARE WHEN REMOVING THIS HOSE AND OPENING V3 VALVE.

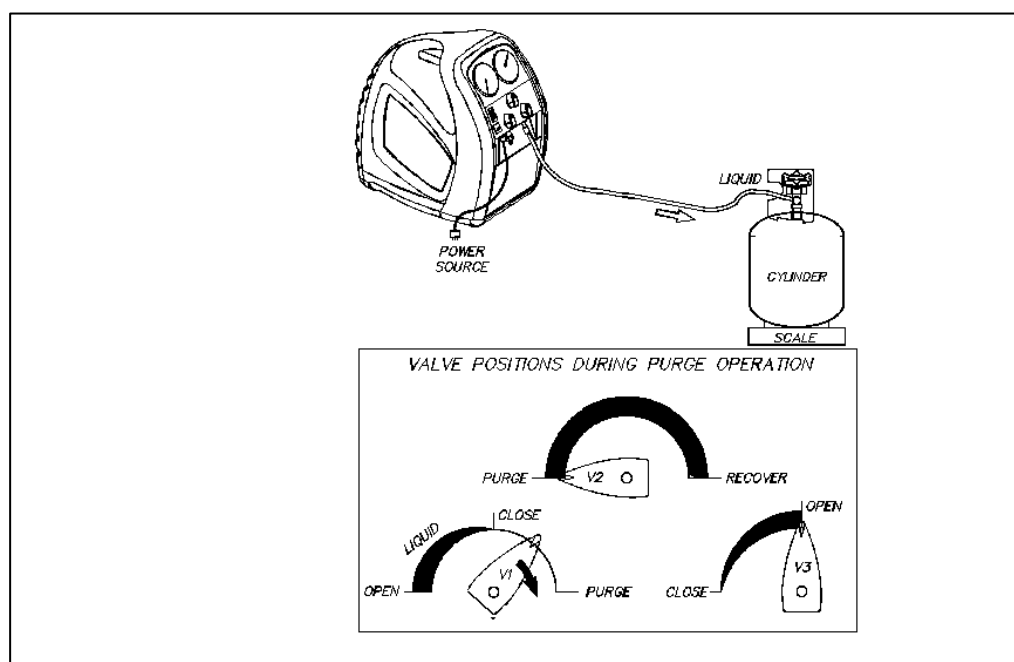

SET-UP PROCEDURE FOR PURGE

3.3.7 REMOVE all hoses and cables and prepare the machine and the recovery cylinder for transport.

3.3.8 When changing refrigerants or reconnecting to a cylinder always purge the hoses and the EVO-HS ports with refrigerant, (or evacuate lines), to prevent air entering the recovery process.

3.3.9  After every operation is complete drain any collected oil from the oil separator by pressing the oil collection bottle to the schrader valve at the rear of the EVO (This is best done while sitting the unit on the edge of a bench or similar). Failure to regularly drain the oil will cause oil to collect in the compressor and/or collection cylinder AND MAY ULTIMATELY LEAD TO COMPRESSOR FAILURE – SEE WARRANTY

- 3.3.10  Check the oil Level periodically. If no oil is visible in the sight glass, Oil must be added. To add oil tilt unit up & unscrew the sight glass & add oil (use a Polyol ester oil). If the oil is overfull, be sure to drain some off, again through the sight glass. Too much or too little oil in the Compressor may lead to irreparable damage.

3.4 SPECIAL OPERATING NOTES

- 3.4.1 During normal operation, when the High Pressure switch activates, the machine will restart automatically when the head pressure drops below approximately 1900 Kpa.
- 3.4.2 **Please note** that the compressor may not start under situations with a low inlet pressure and high discharge pressure. In such circumstance **SWITCH OFF POWER immediately** or motor burn out may occur. Equalise the pressure by turning both the inlet and purge valve (V1 & V2) to “purge”. Allow pressure to equalise before turning valves back to original position & restarting

3.5 STORAGE

- 3.5.1 When the recovery process has been completed, carefully coil the Power Cord, the Refrigerant Hoses ensuring that no dirt or foreign material is left in the ends or on the connectors.
- 3.5.2 Place the EVO-HS in the service vehicle in its upright position and store the hoses and cords nearby. Provide reasonable care to place the unit where it will not be subjected to accidental damage due to shifting items during transit or to heavier objects being placed on its top.
- 3.5.3 The unit can be stored safely in temperatures of 0⁰ - 50⁰ C and humidity levels up to 95% RH. When stored in conditions that are severe, the unit may need to stabilize in the range 10⁰ - 40⁰C before it will offer optimum operating performance. For best results, store the unit in an environmentally controlled area when not in use.
- 3.5.4 Always purge and vent the EVO-HS prior to storage, close V1 & V3 and leave V2 in the Recover Position.

4.0 APPROVED ACCESSORY ITEMS

- 4.1 The EVO-HS Refrigerant Recovery Machine requires the proper accessory items to ensure the best performance. The following items are specifically identified to ensure safety and operational requirements are met. Check with your Wholesaler to ensure that the proper selections have been made.

4.1.1 REFRIGERANT HOSES should be made with approved materials, should be as short as possible to perform the required operations and should have shut-off devices within 300mm of the ends. Approved hoses are:
Refrigerant Hoses with UL Recognition and 20000 Kpa Burst Strength

4.1.2 RECOVERY CYLINDERS should be approved and have an appropriate pressure rating for the refrigerant being recovered. Choose the size (normally 20 or 60 Kg) that is right for the job, and be sure they have a cylinder full float switch. Approved cylinders are:

Refrigerant cylinders with Brad Harrison 3 pin connectors

4.1.3 FILTERS should be selected to protect the Inlet of the EVO-HS from particles of dust, metal and other foreign materials that may be present in the refrigeration system. If servicing a system with a burned out compressor, 2 or more FILTERS in series may be necessary, and they should be discarded immediately after use. Approved filters are:

Filters UL recognized/CSA listed for Refrigeration Service

4.1.4 EXTENSION CORDS, when necessary, should be as short as possible and should contain size 16 AWG (1.291 mm) or larger conductors. This is necessary to avoid overheating during periods of high current draw and minimize the risk of fire. The longer the extension cord required at the work site, the larger the conductor size should be particularly for runs over 10m.

5.0 MAINTENANCE

5.1 Your EVO-HS will provide many seasons of reliable service if it is properly maintained. The actual maintenance requirements are minimal but important.

5.2 Keep the unit clean by wiping it down with a damp cloth to remove dirt, oils, etc. prior to storage for the day. Standard household detergent or isopropyl alcohol may be used if the unit is particularly dirty; in all cases, exercise care to prevent liquids from entering the unit. Gasoline and other solvents are to be avoided as they can damage the EVO-HS's plastic enclosure and they are hazardous.

5.3 Clean inlet particle filter regularly. Discard internal filter screen if it is heavily contaminated and replace with a new screen. Replace screen as per sketch for efficiency.

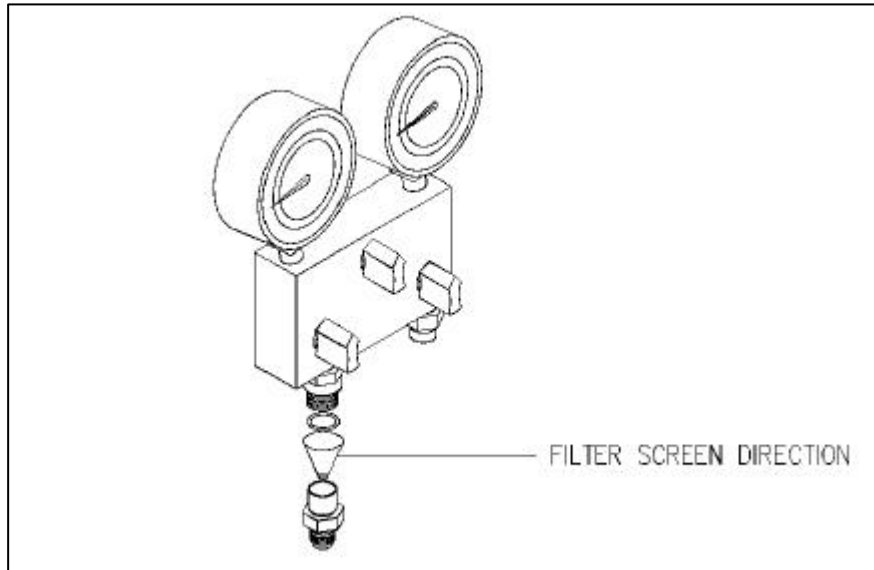

- 5.4 Ensure that the Inlet and Discharge ports are protected and kept clean by replacing the plastic caps after every use. For best results, keep a FILTER permanently connected to the INLET port and change it regularly.
- 5.5 Change HOSES periodically as they develop leaks and a build-up of contaminants over time. Change hoses at least once per season.
- 5.6 When storing the EVO-HS for the season, or for long periods of time, PURGE the unit with an inert gas such as Nitrogen.
- 5.7 When performance falls off it is likely that the compressor seals require replacing. This is normal with use and may occur after a year or two or more often, depending upon the conditions that are prevalent during the recovery operations. Contact your Wholesaler for assistance in selecting the proper maintenance kit.

6.0 TROUBLESHOOTING

PROBLEM	CAUSE	ACTION
Unit will not start- compressor does not start; no light in Power Switch	<input type="checkbox"/> Power Cord not attached <input type="checkbox"/> No voltage at receptacle / incorrect voltage	<input type="checkbox"/> Attach Power Cord <input type="checkbox"/> Verify voltage at Job Site
Compressor will not start	<input type="checkbox"/> Circuit breaker has opened <input type="checkbox"/> Discharge pressure too high <input type="checkbox"/> HP Switch has opened permanently <input type="checkbox"/> Insufficient pressure to close LP switch (if fitted) <input type="checkbox"/> Electronics failure in Motor, Bridge Rectifier or Filter Capacitor / Relay <input type="checkbox"/> Thermal cut-out has activated	<input type="checkbox"/> Identify cause of breaker activation, rectify and reset <input type="checkbox"/> Reduce pressure and rotate V2 to Purge and back to Recovery <input type="checkbox"/> Reduce pressure <input type="checkbox"/> Factory service required <input type="checkbox"/> Check connection, hoses, valves, gauges, system may not contain refrigerant <input type="checkbox"/> Factory service required <input type="checkbox"/> Allow motor to cool. If still not working a factory service is required
Compressor starts but cuts out within a few minutes; pressure indication on HP gauge is high	<input type="checkbox"/> V2 is in Purge position and HP switch activates <input type="checkbox"/> V3 not open and HP switch activates <input type="checkbox"/> Recovery cylinder valve not open <input type="checkbox"/> Blocked discharge hose <input type="checkbox"/> Air in system/cylinder	<input type="checkbox"/> Rotate V2 to Recovery <input type="checkbox"/> Rotate V3 to open position <input type="checkbox"/> Open cylinder valve <input type="checkbox"/> Check & clear blockage <input type="checkbox"/> Bleed air from system/cylinder
Compressor stops intermittently	<input type="checkbox"/> Vapour pressure of refrigerant in cylinder is close to HP trip point	<input type="checkbox"/> Reduce cylinder temperature
Unit overheats	Excessive head pressure due to: <ul style="list-style-type: none"> <input type="checkbox"/> High ambient temperature <input type="checkbox"/> Restricted discharge hose <input type="checkbox"/> Air in recovery cylinder <input type="checkbox"/> Fan not turning 	<input type="checkbox"/> Reduce cylinder temperature <input type="checkbox"/> Check & clear restriction <input type="checkbox"/> Bleed air from cylinder <input type="checkbox"/> Factory service required
Recovery process too slow	<input type="checkbox"/> Head pressure too high <input type="checkbox"/> System refrigerant iced up <input type="checkbox"/> Compressor seals are worn <input type="checkbox"/> Inlet filter blocked	<input type="checkbox"/> Reduce cylinder temperature or change cylinders <input type="checkbox"/> Throttle gauge manifold valves and V3 to reduce pressure differential between LP and HP gauges <input type="checkbox"/> Interrupt process to allow ice to dissipate <input type="checkbox"/> Replace compressor - check with wholesaler for assistance <input type="checkbox"/> Remove filter and clean/replace cone screen

7.0 SERVICE

7.0.1 The EVO-HS uses only UL, CSA or TUV recognized electrical components or components that have been specially designed for this application.

7.0.2  **DO NOT CHANGE** any of these components as the safety of the machine could be compromised. All service work must be performed at a Javac approved facility in order to maintain the safety rating and the Warranty, if applicable.

7.0.3 Technical assistance and service information can be obtained by calling the factory at AUS 1300 786 771. UK (01642)-232-880 or the Organization where you purchased the recovery machine

NOTE: Do not return a defective unit directly to the factory. Contact your Wholesaler or the factory for assistance.

The following Parts and Accessories for your EVO-HS are available through the same dealer from whom you purchased the unit.

REF	PART #	DESCRIPTION	QTY
1	C11142	Hermetic Compressor: 220-240V	1
2	C11141	Axial flow Fan	1
3	C11145	Oil Separator	1
4	D21605	Gauge, HP	1
5	D21603	Gauge, LP	1
6	QD52644	Base Plate	1
7	QC20050	Circuit breaker 4A	1
8	QC20062	Socket, power in	1
9	QC20005	On/Off Switch	1
10	QD52652	Wiring loom	1
11	QA21102	Manifold Assembly	1
12	QS22014	Knob Set (3)	1
13	QS22053	Hose Assembly	1
14	QD52602	Condenser	1
15	QD52654	Housing- blue	1
16	S40570	Oil drain pipe	1
17	QD52617	Front Panel	1
18	QS22020	Manifold Service Kit	1
19	D20808	Cord Set AUS	1
20	QS22054	Inlet Filter Service Kit	1
21	C11144	Pressure switch	1
22	C10054	Polyol ester oil (POE)	1

7.1.5  Only technically qualified personnel who are familiar with basic electronics and refrigeration systems should install the Pressure Control Circuit. Disassembly of the unit to rebuild the compressor or to provide other repair work should be referred to an approved service center as indicated above.

7.2 CONSTRUCTION

- 7.2.1 The Javac EVO-HS is constructed from the highest-grade materials to exacting standards. All assembly and testing is performed in an ISO-9001 Registered facility.
- 7.2.2 This unit is manufactured with environmentally compatible components, which can be substantially recycled at the end of the product's useful life. Consult your local agencies for proper recycling.
- 7.2.3 The EVO-HS contains no hazardous materials.

8.0 RECOVERY CYLINDER SAFETY

- 8.1 Recovery Cylinders are tested to specific requirements to ensure that they will be safe during the transportation process. These requirements ensure the safety of the cylinder when it is filled to an appropriate level and when it is exposed to elevated temperatures, as in a truck or on a hot day outside.
- 8.2 However, a cylinder that is overfilled may still be unsafe, even though the rating is acceptable for the particular refrigerant. It is therefore extremely important, as noted in Sections 1 and 3 of this Manual, to ensure that the cylinder is not overfilled.
- 8.3  The cylinder must not be filled beyond 80% of its capacity. If a scale is to be used, this weight can be determined by taking 80% of the Water Capacity (WC) weight that is marked on the cylinder and adding that to the Tare Weight (TW) of the cylinder. The TW is also marked on the cylinder.
- 8.4 If the cylinder is partially filled and the TW is unknown, then the following **MAXIMUM TOTAL** weights should be used for the recovery process using the weigh scale:

22 Kg Cylinder - Fill to 28Kg, Total Maximum Weight
65 Kg Cylinder - Fill to 75Kg Total Maximum Weight

Part #: QD52653
Issue: 0
Date: 24th November 2003
Pages: 18
File: EVO-HSQD52653.doc

JAVAC PTY LTD

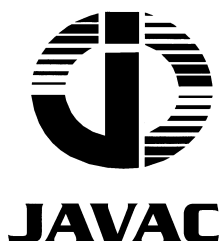

Vacuum & Refrigeration
Process Technology

Head Office 54 Rushdale Street
Knoxfield VIC 3180
Australia
Ph: (03) 9763 7633
Sales Ph: 1300 786 771
Fx: (03) 9763 2756
Email: *sales@javac.com.au*

NSW Unit 19, 159 Arthur Street
Homebush West NSW 2140
Australia
Service Ph: (02) 9746 3536
Sales Ph: 1300 786 771
Fx: (02) 9746 2714
Email: *javacnsw@javac.com.au*

Web: www.javac.com.au

UK Javac (UK) Ltd
6 Drake Court
Britannia Park
Middlesbrough TS2 IRS
England
Ph: (01642) 232 880
Fx: (01642) 232 870
Email: *javac@javac.co.uk*
Web: *www.javac.co.uk*