

# THE NEW GENERATION



VACUUM PUMP SYSTEM

# SC 920

with wireless remote control



**Fast and precise from afar:  
Vacuum pump system  
with wireless remote control**



The new vacuum pump system SC 920 now supports remote control over a portable hand terminal, thus ensuring maximum flexibility in the laboratory. Fast process times and high precision are further outstanding features of this new product.

These days, it is hard to imagine modern laboratories without controller-operated vacuum pump systems. They deliver precise vacuum and offer widely diverse control functions for a huge range of applications in the laboratory.

However, the overall setup, comprising vacuum pump, condenser, separator and vacuum controller, can take up a considerable amount of space in the laboratory.



The new SC 920 vacuum pump system from KNF Lab puts an end to such space problems. Thanks to remote control via a portable wireless hand terminal, it is no longer essential for the vacuum pump system to be located in the immediate vicinity of the processing equipment.

The pump system can now be easily stowed away, i.e. in units under the work bench or in a fume hood, without the hassle of laying cables.

## Enter process parameters via the hand terminal

The hand terminal allows the remote control of the vacuum pump system from your laboratory work station.



The intuitive user guidance on the hand terminal ensures ease of operation; the process parameters can be entered over a touch screen and a rotation knob. Simply touch the various menus to enter:

- parameters, such as the setpoint pressure or suction capacity of the system.
- units of measurement,
- the operating language.

Depending on the selected operating mode, the graphic display of the hand terminal then indicates the respective process variables. The user can intervene in the ongoing process at any time with the hand terminal and its integrated touchscreen and rotating knob.

The hand terminal can be called via vacuum pump system (paging); the hand terminal will answer with a signal tone.

## Four operating modes

The vacuum pump system can be used in four different operating modes, selected on the hand terminal:

■ **Evacuate:**

the vacuum pump system evacuates a vacuum chamber with adjustable pump capacity.

■ **Pressure control:**

the vacuum pump system controls the system pressure to the set value (constant pressure).

■ **Automatic:**

the vacuum pump system automatically finds the vapor pressure of the sample. If there are any irregularities in the pressure curve, the vacuum pump system adjusts the process pressure accordingly.

■ **Individual pressure function:**

the vacuum pump system controls the process according to a user-defined pressure curve. The setpoint pressure and the opening and closing of the coolant valve (accessory) on the high-performance condenser can be easily entered for a range of set times. A repeat function allows successive repetitions of the programmed pressure curve.

At any time during an active process, you can switch to manual process control. Functions for Evacuate and Pressure control will be available simultaneously.

### Intelligent control

A key feature of the SC 920 vacuum pump system is its intelligent control system. A pressure sensor measures the actual pressure in the system several times per second, and a microprocessor monitors any pressure drop over time. The pump speed is adapted according to this information.

At the start of each process, the vacuum pump operates at low speed to avoid over-response in situations with a small vacuum chamber volume and a fast-boiling medium. If there is a large discrepancy between the actual pressure and the setpoint pressure, the pump speed, and thus the transferred volume, is increased in order to speed up the process. As soon as the actual pressure approaches the setpoint pressure, the pump speed is reduced. This ensures fast process times and high control accuracy.

### Controlling via a PC

Included in delivery with the SC 920 is Windows®-based software, which also supports operation of the system over a PC. In addition to the options offered by the hand terminal, the software also supports the display of the pressure curves as a chart (setpoint/actual shown), which can be saved, and the export of data to spreadsheets or text files. Communication with the PC is implemented over a USB interface.





## Fast process times

Besides intelligent control, the diaphragm vacuum pump used in the SC 920 further contributes to short process times. The pump is fitted with the patented diaphragm stabilization system that ensures high suction speeds even at low pressures.

The vacuum pump system achieves an ultimate vacuum of 2 mbar absolute and delivers up to 20 liters of gas per minute. All gas carrying parts are manufactured from chemical resistant materials.

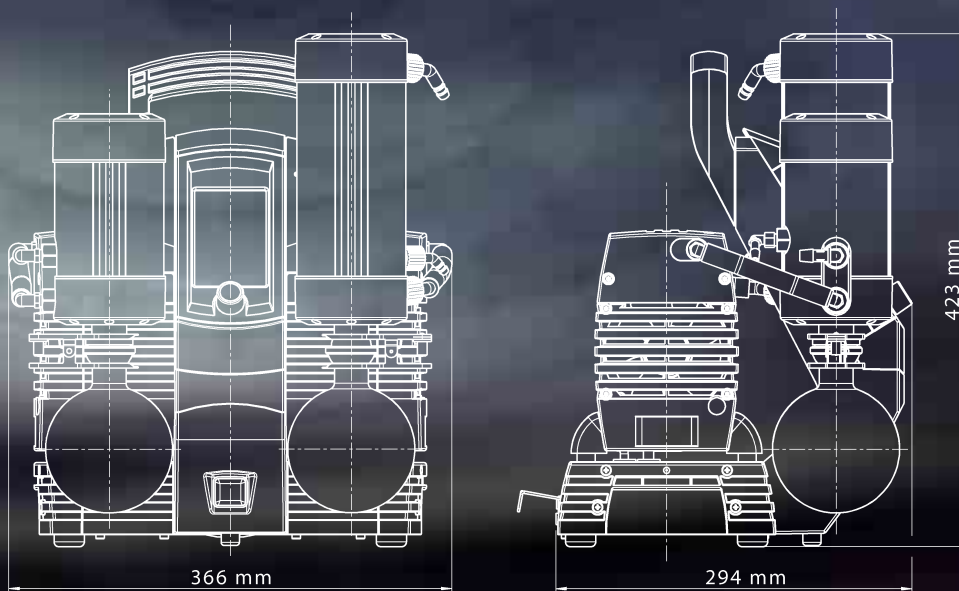

## Extremely quiet operation

The integrated vacuum pump operates extremely quietly. Furthermore the system stops the pump completely as soon as the setpoint pressure of the system is reached and only starts up again intermittently in order to offset any slight drop in pressure due to leakages in the process equipment.

## Perfectly matched components

This vacuum pump system SC 920 opens up a whole new range of options in the laboratory. This is due to new functions and technical solutions. Thanks to the coordinated development of the individual components it has been possible, for example, to adjust the sensitivity of the motor to suit the requirements of the control process.

The SC 920: an extremely user-friendly laboratory device that meets the highest demands.

### Technical data of the SC 920 vacuum pump system

Control	over hand terminal and Windows®-based software
Mains connection:	100 - 240 V, 50 - 60 Hz
Power consumption:	max. 135 W
Hose connections, pneumatic:	ID 10
Hose connections for coolants:	ID 8
Current consumption:	max. 1.7 A
Weight:	15 kg
Dimensions (mm) H x W x D:	423 x 366 x 294

With overcurrent protection and mains fuse

1 Gas outlet	6 Mains switch
2 Connection to vacuum chamber	7 Vacuum pump
3 Coolant outlet	8 Connection coolant valve
4 Coolant inlet	9 USB connection
5 Hand terminal, portable with wireless control	10 Mains connection

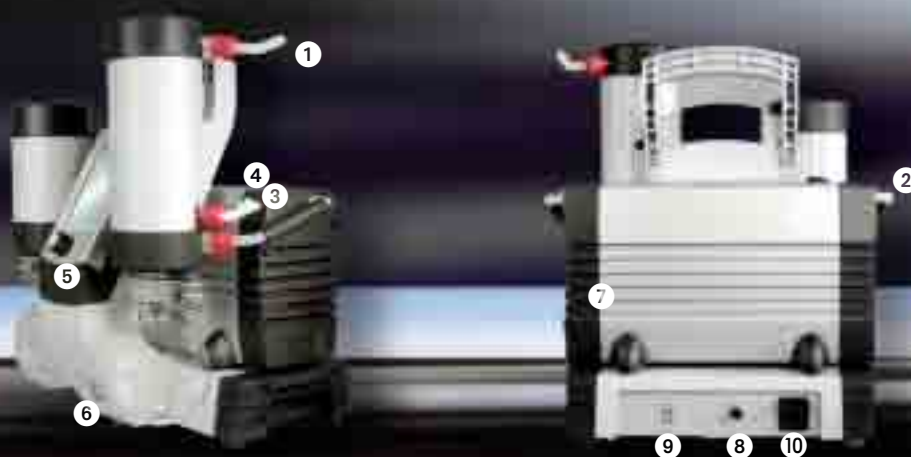

### Performance data

Type	Flow rate (l/min)*	Vacuum (mbar absolut)
SC 920	20	2

\* at atm. pressure

### Accessory

Coolant valve	G 1/2, ID 8	Order No. 117121
---------------	-------------	------------------

Do you have questions?

Please call your KNF Lab application consultant. We will be happy to help.



### KNF Neuberger GmbH Diaphragm Pumps and Systems

Alter Weg 3 · D-79112 Freiburg · Germany  
Tel. 0049(0)7664/5909-0 · Fax 0049(0)7664/5909-99  
E-mail: info@knf.de · www.knf.de