



# Leak Detection Catalog

Edition 2009

**General**

Applications ..... 03

**Products**

**Modular System Leak Detectors**

for universal integration into industrial and automated leak testing systems

T-Guard ..... 04  
 LDS2010 ..... 06  
 Modul1000..... 08  
 Calibrated leaks for system applications ..... 10

**Helium Leak Detectors (vacuum)**

UL1000 ..... 12  
 UL1000 Fab ..... 14  
 UL5000 ..... 16  
 Sample probes and accessories..... 18  
 Calibrated leaks for vacuum applications ..... 20  
 Connection Flanges and Components ..... 21

**Sniffer Leak Detectors**

Helium Sniffer Leak Detectors

Protec P3000 (XL) ..... 22

Refrigerant Sniffer Leak Detectors

Ecotec E3000 ..... 24  
 Ecotec E3000A ..... 26  
 HLD5000..... 28  
 Calibrated test leaks ..... 30



# Applications

Leak Detectors Test Instruments	UL1000	UL1000 Fab	UL5000	LDS2010	T-Guard	Modul1000	Protec P3000	Ecotec E3000	Ecotec E3000A	HLD5000
<b>Applications</b>										
<b>Semiconductor production</b>		◆	◆					◆*)		
<b>Automotive industry</b>	◆			◆	◆	◆	◆	◆		◆
<b>Aircraft construction industry</b>									◆	
<b>Refrigeration</b>	◆						◆	◆		
<b>Air conditioning</b>	◆			◆	◆	◆	◆	◆		◆
<b>Systems engineering</b>	◆			◆	◆	◆				

\*) Gas panels

# Helium Sensor T-Guard for easy Integration into Industrial Leak Testing Systems

INFICON T-Guard™ Leak Detection Sensor delivers the sensitivity and speed helium leak detectors are known for, at a cost similar to pressure decay systems.

It works with simple chambers at atmospheric pressure, so there is no need for costly and complex high vacuum chambers and pumps. That makes automated systems based on T-Guard an attractive alternative to pressure decay and water bath leak detection, providing up to 100 times the sensitivity with low cost of ownership and high ease of use. The measurements are also highly repeatable, even with large, warm or humid test objects.



## USER ADVANTAGES

- Helium leak detection at the price of pressure decay
- Up to 100 times more sensitive than pressure decay and 1,000 times more sensitive than water bath systems ( $10^{-1}$  to  $10^{-6}$  mbar l/s)
- Works at atmospheric pressure — no need for costly vacuum-tight chamber or high vacuum pump
- Maintenance-free INFICON Wise Technology™, proven in more than 1,000 systems
- Faster than pressure decay
- Simple design maximizes reliability, reduces cost of ownership
- Small and light for easy system integration
- Measures big volumes and objects that are warm, humid or cannot stand vacuum
- Measurements not affected by temperature and humidity
- Multiple measurement modes for flexibility
- Designed for automated systems
- Flexible control by PLC, PC or optional display unit
- Storage of parameter settings for easy data transfer on an optional, attachable I-Stick

## TYPICAL APPLICATIONS

- Wherever pressure decay and water bath systems are used or are not sensitive enough
- Leak detection for room air conditioner components and radiators
- Big valves, e.g. for chemical applications
- Manufacturers of automotive gas lines and tanks, small heater coils, etc. that are now demanding greater leak tightness
- Leak detection involving warm, humid or large parts, where the pressure decay method is ineffective
- Other markets where helium vacuum leak detection has been considered too costly or too complex

SPECIFICATIONS	T-GUARD
Minimum detectable leak rate	1 x 10 <sup>-6</sup> mbar l/s
Measurement range	5 decades
Test chamber pressure	1 atm
Operation modes	2 automatic, 1 advanced
Maximum carrier gas flow	1,000,000 sccm
Probe gas flow FINE / GROSS	180 sccm / 90 sccm
Time constant of the leak rate signal	< 1 s
Helium sensor	Wise Technology™
Run up time	< 3 min
Hose connectors	6 mm
Control inputs	6 x PLC compatible (max. 35 V)
Status / Trigger outputs	8 x relay contacts (max. 60 V DC / 25 V AC / 1 A)
Chart recorder output lin/log	2 x 0-10 V, programmable
Recommended fore pump	two-stage diaphragm
Power supply demand	24 V DC
Typical power consumption	< 100 W
Type of protection	IP40
Dimensions (L x W x H)	258 x 130 x 272 mm; 10.2" x 5.1" x 10.7"
Weight	4.5 kg / 10 lbs
Noise level dB (A)	< 56

ORDERING INFORMATION	PART NUMBER
T-Guard™ Leak Detection Sensor	540-001
Options, Accessories	
Display unit for table-top use	551-100
Display unit for rack installation	551-101
Connecting cable for display unit, 1 m	551-103
Connecting cable for display unit, 5 m	551-102
Set of connecting plugs	551-110
Set of connection hoses	200 002 793
Chamber connector	200 002 615
Set of filters	200 001 680
I/O testbox	200 002 490
Power supply	200 002 800
I-Stick	200 001 997

# Modular Leak Detector LDS2010 for System Integration into Industrial Leak Testing Systems

The LDS2010 is a modular helium leak detector for universal integration into industrial leak testing systems. This leak detector was especially designed to speed up industrial leak test processes.

To guarantee a maximum of flexibility in system design the small mass spectrometer and the electronics unit are separate modules. Due to its compact shape the mass spectrometer module can be placed directly at the test chamber of the system. The electronics module that is prepared for a 19" rack system up to ten meters away from the mass spectrometer module.

## USER ADVANTAGES

- Very fast signal response time due to a very high helium pumping speed
- No loss of pumping speed caused by long connection tubes between the system and the leak detector, as the small mass spectrometer module can be placed close to the vacuum chamber
- The rugged and reliable high compression turbo pump
  - makes the unit insusceptible for rising helium back-grounds caused by contaminated roughing pumps
  - allows the use of cost -effective single stage roughing pumps.
- Short pumping time due to a high max. inlet pressure (20 mbar)
- Variety of data control and acquisition options via:
  - RS232
  - RS485
  - PLC
  - Profibus compatible with optional converter
  - Lin/log chart recorder
- Rugged mass spectrometer system with dual filament ion source (3 years warranty) ensures high uptime and low maintenance cost
- Switching over from vacuum leak detection to sniffer leak detection allows for immediate pin-pointing of the leak during the same test step
- Calibration via internal calibrated leak; also external or dynamic calibration is possible while pumping down is in progress (faster start-up)

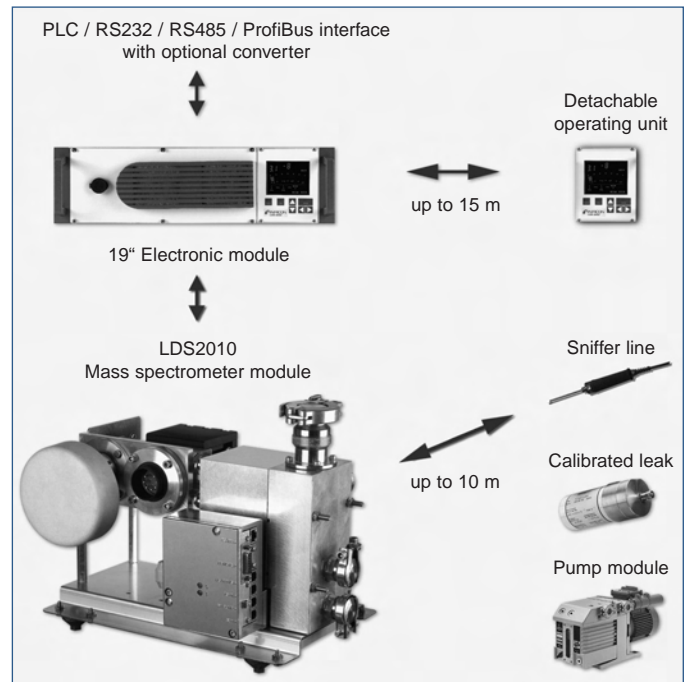

System schematics LDS2010

## TYPICAL APPLICATIONS

The flexibility of the LDS2010 makes the instrument ideal for the integration into complex helium leak detection systems.

- Airbag parts
- Evaporators, condensers, compressors
- Valves
- Brake lines, fuel lines
- Hydraulic components
- Engines

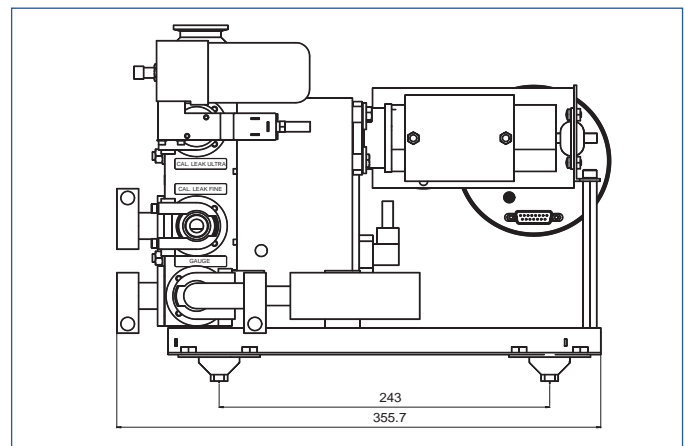

Dimensional drawing of the mass spectrometer module in mm (inch).

SPECIFICATIONS	LDS2010
Minimum detectable leak rate: ULTRA mode FINE mode GROSS mode SNIFFER mode	$\leq 2 \cdot 10^{-11}$ mbar l/s (5 l/s Helium pumping speed) $\leq 2 \cdot 10^{-10}$ mbar l/s (1.7 l/s Helium pumping speed) $\leq 8 \cdot 10^{-8}$ mbar l/s $\leq 5 \cdot 10^{-8}$ mbar l/s
Units of measurement (selectable)	mbar l/s, Pa m <sup>3</sup> /s, atm cc/s, g/a, ppm
Maximum inlet pressure	20 mbar (FINE 3 mbar, ULTRA 0.4 mbar)
Response time	< 1 s
Ion source	2 longlife Iridium filaments, Yttrium-oxide coated
Vacuum connections	DN 16 KF / DN 25 KF
Relays	4
Control inputs	PLC compatible (max. 35 V)
Chart recorder output lin/log	0 - 10 V
Interface	RS232, RS485, and Fieldbus options
Dimensions (L x W x H) Mass spectrometer module Electronics module	348 x 244 x 267 mm (13.7 x 9.6 x 10.5 in.) 482.6 x 359.9 x 134.1 mm (19 x 14.17 x 5.28 in.)
ORDERING INFORMATION	PART NUMBER
LDS2010 consisting of electronic module with integrated operating unit and mass spectrometer	560-100
LDS2010 consisting of electronic module with integrated operating unit and mass spectrometer and 10 m cable	560-101
Connecting cable: Electronic module / mass spectrometer module 1.5 m (4.8 ft.) 3 m (10 ft.) 5 m (16 ft.) 10 m (32 ft.) incl. MSV board	560-111 560-112 560-113 560-114
Options:	
Pump module (complete with connection accessories) TRIVAC D 4 B, single-phase motor, 230 V, 50/60 Hz	145 11
Sniffer valve	145 20
Sniffer line, incl. handle with sniffer tip, 200 mm	
Line lengths:	
3 m (10 ft.)	145 21
5 m (16 ft.)	145 22
10 m (32 ft.)	145 23
Replacement sniffer probe, 400 mm length	200 04 642
Connecting cable	
Electronics module / operating unit 5 m (16 ft.) 10 m (32 ft.) 15 m (48 ft.)	146 40 146 41 146 42
Internal calibrated leak TL7	145 49
Profibus converter TIC255	560-021

# Helium Leak Detector Modul1000

Building up a leak test bench was never easier. The Modul1000 is the world first leak detector that fulfills jobs which are normally done by a PLC. The detector itself provides all necessary valves for a vacuum leak test and controls the complete leak test process from charging the test object with helium until venting of the test chamber.

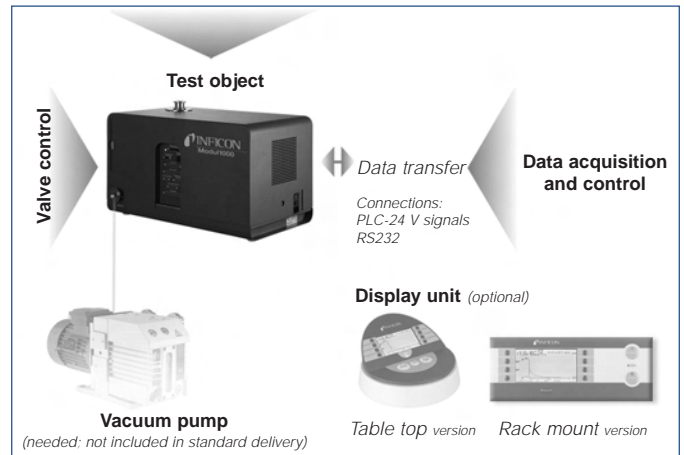

Modul1000 system schematics

## USER ADVANTAGES

- Implemented “Commander” software menu for direct control of test benches and the complete leak test process.
- Easy to operate
- The choice between two different types of optional display units which can be placed away from the main unit for a maximum flexibility in test bench design.
- Low impact for rising helium background and contamination as a consequence of the high compression ratio of the turbo molecular pump
- The high compression turbo molecular pump allows the use of cost-effective single stage roughing pumps.
- Rugged mass spectrometer system with dual filament ion source (3 years warranty) ensures high uptime and low maintenance cost
- Switching over from vacuum leak detection to sniffer leak detection allows for immediate pin-pointing of the leak during the same test step

## TYPICAL APPLICATIONS

The Modul1000 was especially designed for the integration into medium automated test benches.

- Evaporators, condensers, compressors
- Valves
- Brake lines, fuel lines
- Hydraulic components
- Engines

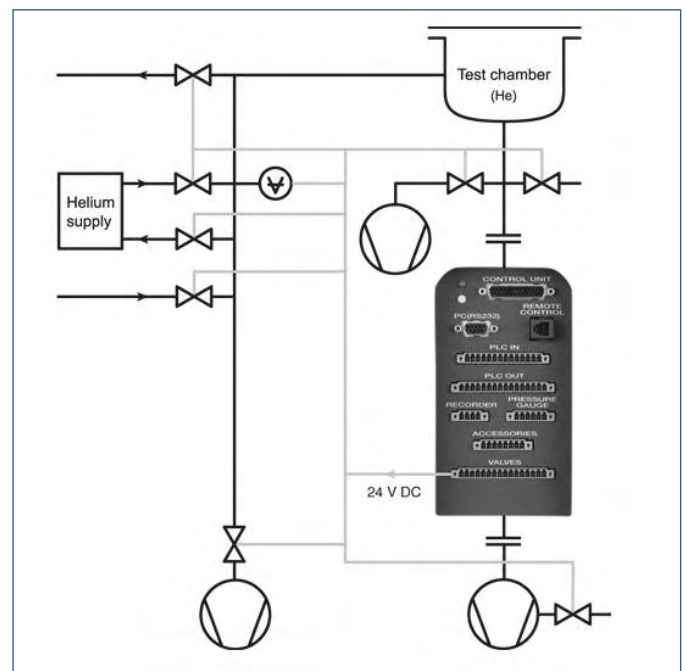

Example: Test station with Helium supply. Implemented “Commander” software menu for direct control of test systems

<b>SPECIFICATIONS</b>	<b>MODUL1000</b>
Minimum detectable leak rate VACUUM mode	< 5 x 10 <sup>-12</sup> mbar l/s
SNIFFER mode	< 5 x 10 <sup>-8</sup> mbar l/s
Maximum inlet pressure	0.4 mbar 3 mbar (Modul1000b)
Operational mode	wide range without crossover (12 decades)
Helium pumping speed at inlet	2.5 l/s 0.1 l/s (Modul1000b)
Ion source	2 longlife Iridium filaments, Yttrium-oxide coated
Start-up time	< 3 minutes
Inlet port / Fore-vacuum port	DN 25 KF
Power supply	100 - 240 V, 50/60 Hz
Control inputs	8 x PLC compatible (max. 35 V)
Status / Valve control / Trigger outputs	9 / 11 / 3 x relay contacts (max. 60 V AC / 25 V DC / 1 A)
Chart recorder output lin/log	2 x 0-10 V, programmable
Recommended fore-vacuum pump	2.5 - 16 m <sup>3</sup> /h, wet or dry
Dimensions (width x depth x height)	535 x 350 x 339 mm (21.1 x 13.8 x 13.4 in)
Weight	30 kg (66 lbs)

<b>ORDERING INFORMATION</b>	<b>PART NUMBER</b>
Modul1000, vacuum version	550-300
Modul1000, vacuum and sniffer version	550-310
Modul1000b, vacuum and sniffer version	550-330
Display unit for table-top use	551-100
Display unit for rack installation	551-101
Connecting cable for display unit, 1 m	551-103
5 m	551-102
Set of connecting plugs	551-110
Sniffer line SL200	140 05
Hand unit	200 99 022
Connecting cable for hand unit, 4 m	200 99 027
Test chamber TC1000	551-005

# Calibrated Leaks for System Applications

Manufacturers of helium leak testing systems require calibrated leaks of various sizes with individually adjusted leak rates for the purpose of setting up and calibrating their systems.

Depending on the type of application, these calibrated leaks are either installed in the test sample as a master leak or are installed in the test chamber itself.

INFICON offers calibrated leaks which are capable of meeting the requirements concerning type and required leak rate.



Integral test leak

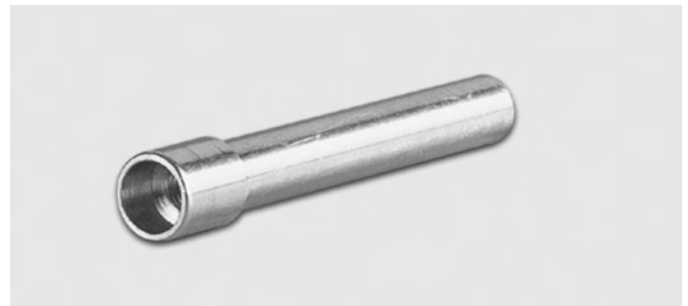

Calibrated leaks with screw-in sleeve

## USER ADVANTAGES

- Customer-specific leak rate
- Simple to operate
- Easy to install
- Ideal installation dimensions
- All calibrated leaks are supplied with a factory certificate indicating their leak rate

## TYPICAL APPLICATIONS

- As a master calibrated leak built directly into the test sample
- Directly installed to the test chamber
- Use as a calibrated leak for sniffer applications

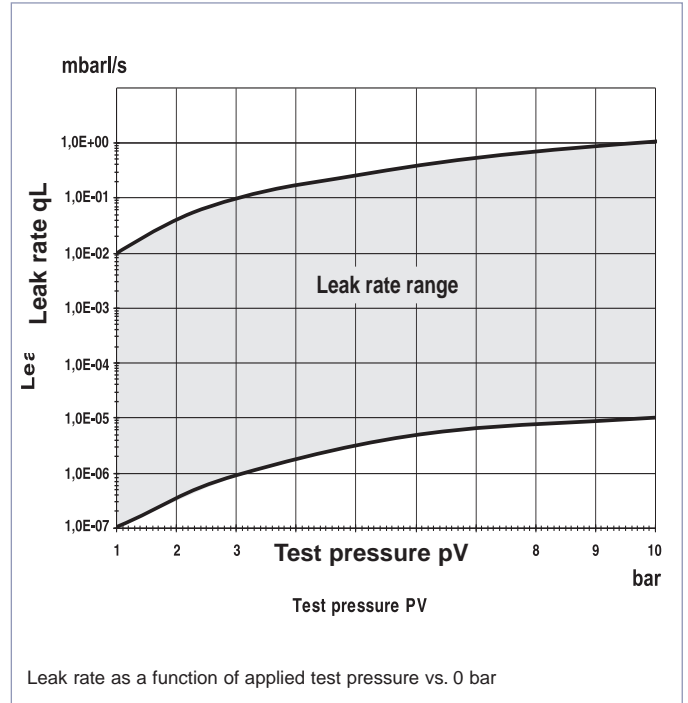

## CALIBRATED INTEGRAL LEAK WITH HELIUM RESERVOIR

The integral Helium test leak is for use in a vacuum test chamber and is designed for easy filling and refilling by the customer. It is used for

- Calibration of the vacuum system
- Evaluation of the machine factor for the system
- Verification of the test procedure

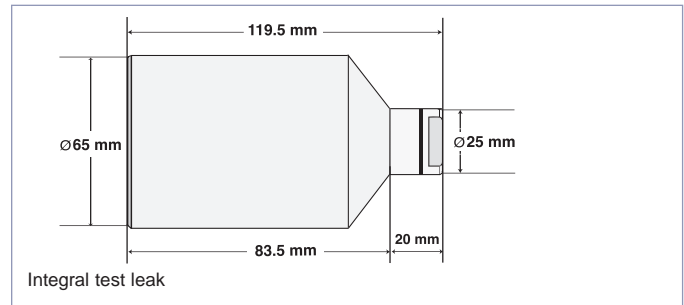

## CALIBRATED LEAK WITH SCREW-IN SLEEVE

Used as a master leak to check the entire helium leak testing system.

Two leak tight test samples are equipped with these calibrated leaks. These will ensure proper separation between passed and rejected parts. To be fitted to the customer's test samples either by a welded joint or the screw-in sleeve is glued in place.

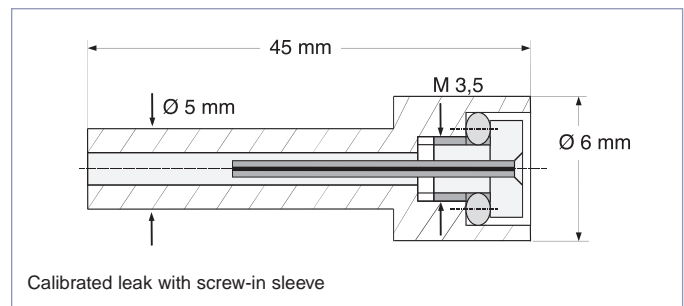

## CALIBRATED LEAK WITH PIN TYPE CASING TL4, TL6, TL4-6

TL4 and TL6: Helium calibrated leaks without gas reservoir (capillary type of leak) for sensitivity and signal response time determinations during vacuum leak detection. A purging valve with hose nozzle permits a rapid exchange of the gas in the dead volume.

TL4-6: Helium calibrated leak (capillary leak) for gross leaks with exchangeable helium reservoir, pressure gauge and two manually operated valves. For calibration of leak rate readings and the alignment of helium mass spectrometers in the vacuum pressure range.

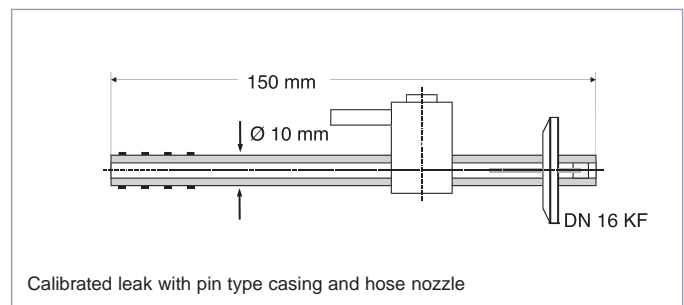

## ORDERING INFORMATION

CALIBRATED INTERNAL LEAK	MAX. OPERATING PRESSURE	PART NUMBER
Integral test leak	1 bar against vacuum	143 15S
Calibrated leak with screw-in sleeve, Ø 5 mm	20 bar (up to 40 bar if the capillary is glued-in by the customer)	143 00
Calibrated leak with screw-in sleeve, Ø 6 mm	20 bar (up to 40 bar if the capillary is glued-in by the customer)	143 16
CALIBRATED LEAK	LEAK RATE RANGE	PART NUMBER
TL 4, without helium gas reservoir	$10^{-4}$ mbar l/s	155 65
TL 6, without helium gas reservoir	$10^{-6}$ mbar l/s	155 66
TL 4-6, with helium gas reservoir	$10^{-4}$ to $10^{-6}$ mbar l/s	155 80

# Helium Leak Detector UL1000

The mobile UL1000 with a rotary vane pump is an automated leak detector offering fast pumpdown and short response time for quick testing results in industrial systems.



## USER ADVANTAGES

- Wide measurement range over 15 decades
- Short pumpdown and response time
- Mobile all metal housing for added convenience with uncompromised maneuverability
- **I-CAL** ( Intelligent **C**alculation **A**lgorithm for **L**eak rates ) to ensure fastest response time to leaks in all measurement ranges
- Zero function with automatic integration time alignment for fast and reliable test results
- Intelligent vacuum design with rugged roughing pump and multiple inlet turbomolecular pump that provides high helium pumping speed with high compression
- Rotatable display and user interface allows simple and easy control and interaction with the unit
- Self protection features to protect the UL1000 from helium and particle contamination
- Auto purge cycle to ensure clean up and readiness for test
- Software updates via email easily possible
- Rugged mass spectrometer system with 2 filament ion source (3 years warranty) ensures long running time and low maintenance cost
- Built-in test leak for internal calibration to ensure accurate test results
- Built-in software menu “Auto Leak Test” function to perform tests of hermetically sealed components. By use of the optional test chamber TC1000 (see page 19) this test runs automatically

## TYPICAL APPLICATIONS

Leak testing and quality control of all types of components including

- Automotive components
- Refrigeration and air conditioning components and sub-assemblies
- Hermetically sealed electronic devices
- Heat exchangers

### Advanced software menu Auto Leak Test

This function controls the test cycle and allows entering of test parameters like

- measuring cycle time
- trigger level
- number of parts tested

The status of the test cycle can always be monitored on the display. The optional test chamber TC1000 (see page 36) turns the UL1000 in a user-friendly workstation for the test of hermetically sealed parts.

The test starts automatically when closing the chamber lid, short cycle times can be achieved ( $10^{-9}$  mbar l/s in < 5 sec). The status of the test can always be monitored on the display. After the adjusted cycle time the test stops and the chamber will be vented. A selectable “Standby” mode keeps the chamber under vacuum while discontinuing the leak test. Protective functions prevent helium contamination by big leaker and ensure continuous operation.

SPECIFICATIONS	UL1000
Min. detectable leak rate for helium (Vacuum mode) *)	< 5 x 10 <sup>-12</sup> mbar l/s
Min. detectable leak rate for helium (Sniffer mode) *)	< 5 x 10 <sup>-8</sup> mbar l/s
Max. detectable leak rate for helium that can be displayed	0.1 mbar l/s
Max. inlet pressure	GROSS mode: 15 mbar FINE mode: 2 mbar ULTRA mode: 0.4 mbar
Pumping speed during evacuation	16 m <sup>3</sup> /h (11.2 cfm) at 50 Hz
Helium pumping speed	GROSS mode: max. 8 l/s FINE mode: 7 l/s ULTRA mode: 2.5 l/s
Time constant of the leak rate signal (blanked off, 63% final value)	< 1 s
Pumpdown time until ready to detect leaks (Background 5 x 10 <sup>-9</sup> )	
Without additional volume	5 s
At a test volume of 1 litre	10 s
At a test volume of 10 litre	80 s
Response time (for a leak rate of 10 <sup>-9</sup> mbar l/s)	
Up to a volume of 1 litre	< 1 s
Up to volume of 10 litre	< 2 s
Time until ready for operation	< 3 min
Detectable masses	2,3,4 amu, H <sub>2</sub> , <sup>3</sup> He, He
Mass spectrometer	180° magnetic sector field
Ion source	2 filaments, Iridium/Yttria oxide coated
Calibrated leak TL7 (built-in) leak rate in the range	10 <sup>-7</sup> mbar l/s
Units of measurement (selectable)	mbar l/s, Pa m <sup>3</sup> /s, Torr l/s, atm cc/s, ppm, g/a (only in sniffer mode)
Test port	25 KF
Adjustable triggers	2
Interface	RS 232
In/outputs	PLC compatible for control and status information
Chart recorder output	2 x 10 V
Supply voltages	230 V (±10%) 50 Hz 115 V (±10%) 60 Hz 100 V (±10 %) 50/60 Hz
Power consumption	1100 VA
Dimensions (L x W x H)	1068 x 525 x 850 mm (42 x 21 x 33 inch)
Weight	110 kg (242 lbs)
Type of protection	IP 40
Permissible ambient temperature (during operation)	+10 °C .....+40 °C
*) per AVS and EN 1518	
ORDERING INFORMATION	PART NUMBER
UL1000, 230 Volts, 50 Hz, EU mains plug	550-000
UL1000, 115 Volts, 60 Hz, US mains plug	550-001
UL1000, 110 Volts, 60 Hz, Japan mains plug	550-002
Test Chamber TC1000 incl. ESD wrist band	551-005
Test leak adapter for TC1000, DN 25 KF flange	200 001 797
Remote control kit	
Hand unit	200 99 022
Cable (required), 4 m length	200 99 027
Extension cable, 10 m (max length of extension 34 m)	140 22
Accessories:	
Toolbox with lock, attachable	551-000
Helium bottle holder	551-001
ESD mat	551 002
Sniffer line SL200, 4 m length	140 05
LeakWare PC software package	140 90

# Dry Helium Leak Detector UL1000 Fab

The mobile UL1000 Fab with its dry vacuum system is an automatic leak detector offering fast pumpdown and short response time to meet the demanding requirements in semiconductor applications.



## USER ADVANTAGES

- Wide measurement range over 15 decades
- Short pumpdown and response time
- Mobile all metal housing for added convenience with uncompromised maneuverability
- **I-CAL (Intelligent Calculation Algorithm for Leak rates)** to ensure fastest response time to leaks in all measurement ranges
- Zero function with automatic integration time alignment for fast and reliable test results
- Intelligent vacuum design with rugged scroll pump and multiple inlet turbomolecular pump that provides high helium pumping speed with high compression
- Rotatable display and user interface allows simple and easy control and interaction with the unit
- Self protection features to protect the UL1000 Fab from helium and particle contamination
- Auto purge cycle to ensure clean up and readiness for test
- Software updates via email easily possible
- Rugged mass spectrometer system with 2 filament ion source (3 years warranty) ensures long running time and low maintenance cost
- Built-in test leak for internal calibration to ensure accurate test results
- Built-in software menu "Auto Leak Test" function to perform tests of hermetically sealed components. By use of the optional test chamber TC1000 (see page 19) this test runs automatically

## TYPICAL APPLICATIONS

- Leak testing of
  - Components
  - Chambers
  - Subassemblies
- used on
  - Semiconductor tools
  - Flat display tools
- Leak testing of hermetically sealed electronically devices

### Advanced software menu Auto Leak Test

This function controls the test cycle and allows entering of test parameters like

- measuring cycle time
- trigger level
- number of parts tested

The status of the test cycle can always be monitored on the display. The optional test chamber TC1000 (see page 36) turns the UL1000 in a user-friendly workstation for the test of hermetically sealed parts.

The test starts automatically when closing the chamber lid, short cycle times can be achieved ( $10^{-9}$  mbar l/s in < 5 sec). The status of the test can always be monitored on the display. After the adjusted cycle time the test stops and the chamber will be vented. A selectable "Standby" mode keeps the chamber under vacuum while discontinuing the leak test. Protective functions prevent helium contamination by big leaker and ensure continuous operation.

SPECIFICATIONS	UL1000 FAB
Min. detectable leak rate for helium (Vacuum mode) *)	< 5 x 10 <sup>-12</sup> mbar l/s
Min. detectable leak rate for helium (Sniffer mode) *)	< 5 x 10 <sup>-8</sup> mbar l/s
Max. detectable leak rate for helium that can be displayed	0.1 mbar l/s
Max. inlet pressure	GROSS mode: 15 mbar FINE mode: 2 mbar ULTRA mode: 0.4 mbar
Pumping speed during evacuation	25 m <sup>3</sup> /h (17.6 cfm) at 50 Hz 30 m <sup>3</sup> /h (21.1 cfm) at 60 Hz
Helium pumping speed	GROSS mode: max. 8 l/s FINE mode: 7 l/s ULTRA mode: 2.5 l/s
Time constant of the leak rate signal (blanked off, 63% final value)	< 1 s
Pumpdown time until ready to detect leaks (Background 5 x 10 <sup>-9</sup> )	
Without additional volume	5 s
At a test volume of 1 litre	10 s
At a test volume of 10 litre	80 s
Response time (for a leak rate of 10 <sup>-9</sup> mbar l/s)	
Up to a volume of 1 litre	< 1 s
Up to volume of 10 litre	< 2 s
Time until ready for operation	< 3 min
Detectable masses	2,3,4 amu, H <sub>2</sub> , <sup>3</sup> He, He
Mass spectrometer	180° magnetic sector field
Ion source	2 filaments, Iridium/Yttria oxide coated
Calibrated leak TL7 (built-in) leak rate in the range	10 <sup>-7</sup> mbar l/s
Units of measurement (selectable)	mbar l/s, Pa m <sup>3</sup> /s, Torr l/s, atm cc/s ppm, g/a (only in sniffer mode)
Test port	25 KF
Adjustable triggers	2
Interface	RS 232
In/outputs	PLC compatible for control and status information
Chart recorder output	2 x 10 V
Supply voltages	230 V (±10%) 50 Hz 115 V (±10%) 60 Hz 100 V (±10 %) 50/60 Hz
Power consumption	1100 VA
Dimensions (L x W x H)	1068 x 525 x 850 mm (42 x 21 x 33 inch)
Weight	110 kg (242 lbs)
Type of protection	IP 40
Permissible ambient temperature (during operation)	+10 °C .....+40 °C
*) per AVS and EN 1518	
ORDERING INFORMATION	PART NUMBER
UL1000 Fab, 230 Volts, 50 Hz, EU mains plug	550-100
UL1000 Fab, 100/115 Volts, 50/60 Hz, US mains plug	550-101
Test Chamber TC1000 incl. ESD wrist band	551-005
Test leak adapter for TC1000, DN 25 KF flange	200 001 797
Remote control kit	
Hand unit	200 99 022
Cable (required), 4 m length	200 99 027
Extension cable, 10 m (max length of extension 34 m)	140 22
Accessories:	
Toolbox with lock, attachable	551-000
Helium bottle holder	551-001
ESD mat	551 002
Sniffer line SL200, 4 m length	140 05
LeakWare PC software package	140 90

# Dry Helium Leak Detector UL5000

The mobile UL5000 is designed to meet the most critical and demanding semiconductor applications, providing fast pumpdown time and delivering fast response time.

It is an ideal tool for bigger testing volumes > 50 l volume.



## USER ADVANTAGES

- Wide measurement range over 15 decades
- Short pumpdown and response time
- Mobile all metal housing for added convenience with uncompromised maneuverability
- Software algorithm **HYDRO-S (HYDROgen-Suppression)** to enable test conditions to be reached quickly
- **I-CAL (Intelligent Calculation Algorithm for Leak rates )** to ensure fastest response time to leaks in all measurement ranges
- Zero function with automatic integration time alignment for fast and reliable test results
- Intelligent vacuum design with rugged Scroll pump and multiple inlet turbomolecular pump that provides high helium pumping speed with high compression
- Rotatable display and user interface allows simple and easy control and interaction with the unit
- Self protection features to protect the UL5000 from helium and particle contamination
- Auto purge cycle to ensure clean up and readiness for test
- Software updates via email easy possible
- New workstation design with optimal height work surface that includes an ESD mat and a lockable tool box
- Rugged mass spectrometer system with 2 filament ion source (3 years warranty) ensures long running time and low maintenance cost
- Built-in test leak for internal calibration to ensure accurate test results

## TYPICAL APPLICATIONS

Leak testing of

- Components
  - Bigger chambers (> 50 l volume)
  - Subassemblies
- used on
- Semiconductor tools
  - Flat display tools

SPECIFICATIONS	UL5000
Min. detectable leak rate for helium (Vacuum mode) *)	$< 5 \times 10^{-12}$ mbar l/s
Min. detectable leak rate for helium (Sniffer mode) *)	$< 5 \times 10^{-8}$ mbar l/s
Max. detectable leak rate for helium that can be displayed	3 mbar l/s
Max. inlet pressure	GROSS mode: 15 mbar FINE mode: 2 mbar ULTRA mode: 0.4 mbar
Pumping speed during evacuation	25 m <sup>3</sup> /h (17.6 cfm) at 50 Hz 30 m <sup>3</sup> /h (21.1 cfm) at 60 Hz
Helium pumping speed	GROSS: max. 8 l/s FINE: max. 20 l/s ULTRA: > 20 l/s
Time constant of the leak rate signal (blanked off, 63% final value)	< 1 s
Pumpdown time until ready to detect leaks in the range of 10 <sup>-9</sup> mbar l/s	
Without additional volume	< 5 s
At a test volume of 10 litre	< 48 s
At a test volume of 50 litre	< 150 s
Response time (for a leak rate of 10 <sup>-9</sup> mbar l/s )	
Up to a volume of 10 litre	< 1 s
Up to volume of 50 litre	< 2 s
Venting (with test volume of 100 litres)	approx. 25 s
Time until ready for operation	< 3 min
Detectable masses	2,3,4 amu, H <sub>2</sub> , <sup>3</sup> He, He
Mass spectrometer	180° magnetic sector field
Ion source	2 filaments, Iridium/Yttria oxide coated
Calibrated leak TL7 (built-in) leak rate in the range	10 <sup>-7</sup> mbar l/s
Units of measurement (selectable)	mbar l/s, Pa m <sup>3</sup> /s, Torr l/s, atm cc/s ppm, g/a (only in sniffer mode)
Test port	40 KF
Adjustable triggers	2
Interface	RS 232
In/outputs	PLC compatible for control and status information
Chart recorder output	2 x 10 V
Supply voltages	230 V (±10%) 50 Hz 115 V (±10%) 60 Hz 100 V (±10%) 50/60 Hz
Power consumption	1200 VA
Dimensions (L x W x H)	1080 x 530 x 1083 mm (42.5 x 21 x 42.6 inch)
Weight	140 kg (308 lbs)
Type of protection	IP 40
Permissible ambient temperature (during operation)	+10 °C .....+40 °C
*) per AVS and EN 1518	
ORDERING INFORMATION	PART NUMBER
UL5000, 230 Volts, 50 Hz, EU mains plug	550-500
UL5000, 100/115 Volts, 50/60 Hz, US mains plug	550-501
all UL5000 including Tool box and ESD mat	
Remote control kit	
Hand unit	200 99 022
Cable (required), 4 m length	200 99 027
Extension cable, 10 m (max length of extension 34 m)	14022
Accessories:	
Helium bottle holder	551-001
LeakWare PC software package	140 90
Sniffer Line SL200, 4 m	14005
Reduction piece 40/25 KF to connect SL200 to UL5000 inlet port	211-283

# Accessories for Vacuum Leak Detectors

## HELIUM SNIFFER LINE SL200 FOR THE UL1000/5000 AND MODUL1000

Helium sniffers in connection with the UL1000, UL5000 and the Modul1000 leak detectors are used for leak testing test samples which are pressurized with Helium.

Besides pinpointing the leaks, it is possible to determine the leak rate of the escaping helium.

- Sniffer line connects directly to the inlet port
- Very fast response time < 1 sec
- Extremely low detection limit < 1 x 10<sup>-7</sup> mbar l/s
- Rigid 120 mm sniffer tip (included)
- Connecting flange DN 25 KF



Helium sniffer line SL 200 P

## HELIUM SNIFFERS QUICK-TEST QT100 FOR THE UL1000/5000, AND THE MODUL1000

- For greater distances up to 20 m between test object and leak detector
- Diaphragm pump for sucking the search gas
- Minimum detectable leak rate 1 x 10<sup>-6</sup> mbar l/s
- Short response and decay times: 1 sec at 5 m, 8 sec at 20 m
- High sniffer velocity
- Built-in transformer for adaptation to any required power supply voltage 110-230 V AC



Helium sniffer QUICK-TEST QT 100 with sniffer

### SPECIFICATIONS

	SAMPLE PROBES	
	SL200	QT100
Minimum detectable leak rate	< 10 <sup>-7</sup> mbar l/s	10 <sup>-6</sup> mbar l/s
Supply voltage	-	110 - 220 V, 50/60 Hz
Signal response time, approx.		
	at a length of 5 m	1 s
	20 m	8 s
Connection flange	DN 25 KF	DN 25 KF
Weight	0.6 kg (1.32 lbs)	3.5 kg (7.72 lbs)

### ORDERING INFORMATION

	PART NUMBER
Helium sniffer line, SL200 P, 4 m long, straight handle with red / green LED for go / no-go indication, rigid sniffer tip 120 mm	140 05
Helium sniffer QUICK-TEST QT100	155 94
Sniffer line for the QT100,	
5 m	140 08
20 m	140 09

## SEARCH GAS SPRAY GUN

The search gas spray gun with PVC hose (5 m long) is used for well aimed spraying of search gas at places where a leak is suspected.



Search gas spray gun

## LEAKWARE

### ORDERING INFORMATION

### PART NUMBER

Search gas spray gun	165 55
Rubber bladder (Helium reservoir for spray gun)	200 20 218
Hose clamp for rubber bladder	200 20 217
PC software LeakWare	140 90

## TEST CHAMBER TC1000 FOR THE UL1000/UL1000 FAB AND MODUL1000

- Turns the UL1000 / UL1000 FAB and the Modul1000 into a reliable and user-friendly workstation for testing of hermetically sealed parts (also according to MIL-STD 843, Method 1014)
- Easy to install
- Maintenance-free
- Volume (hemispherical shape): approx. 430 ccm
- Upper diameter / depth: 130 / 40 mm
- Material: Aluminum alloy, low outgasing rate
- Weight: 2.5 kg
- Vacuum connection: DN 25 KF
- Integrated sensor switch to start test in combination with UL1000 / UL1000 Fab and the Modul1000
- Clearly visible red/green LED's to display test results
- Calibration by an external test leak easy possible by using an optional adapter plate
- Protection of tested parts against static discharge by the standard ESD wrist band and an optional ESD mat (Cat. No. 551-002) for UL1000 / UL1000 Fab



Test chamber TC1000



TC1000 in operation; exemplary menu function showed on the display

### ORDERING INFORMATION

### PART NUMBER

Test chamber TC1000 incl. ESD wrist band	551-005
Test leak adapter for TC1000, DN 25 KF flange	200 001 797

## Calibrated Test Leaks with Gas Reservoir for Vacuum Applications

### TL7

Capillary leak with helium reservoir and manual valve.  
Leak rate range  $10^{-7}$  mbar l/s. Connecting flange DN 10 KF.

### TL8 / TL9

Helium test leak with helium reservoir and manual valve.  
A special quartz bulb with a high helium permeation rate adjusts the constant gas flow. Connecting flange DN 10 KF.



### USER ADVANTAGES

- Inured to pollution
- Metal-free flow reduction for low temperature dependence
- Inspection certificate (included) in accordance to DIN EN 10204:2004-3.1
- Highly accurate and reliable
- Determination of the nominal leak rate by comparison with a calibrated leak having a PTB certificate
- DKD certificate (optional) traceable to PTB

### ORDERING INFORMATION

CALIBRATED LEAK	LEAK RATE RANGE	PART NUMBER
TL 7, with helium gas reservoir	$10^{-7}$ mbar l/s	142 10 / 115 14
TL 8, with helium gas reservoir	$10^{-8}$ mbar l/s	165 57
TL 8, with helium gas reservoir, DKD calibrated	$10^{-8}$ mbar l/s	165 57DKD
TL 9, with helium gas reservoir	$10^{-9}$ mbar l/s	144 08

## Calibrated Test Leaks with Gas Reservoir for Vacuum and Sniffer Applications

### TL4-6

Universal gas source for the fast insert in a variety of applications

Helium capillary leak for vacuum and sniffing applications.  
Adjustable leak rate in the range between  $10^{-4}$  to  $10^{-6}$  mbar l/s. Besides helium, which is included in delivery, the TL4-6 is also usable with different kind of gases.



### ORDERING INFORMATION

CALIBRATED LEAK	LEAK RATE RANGE	PART NUMBER
TL4-6, with helium gas reservoir	$10^{-4}$ to $10^{-6}$ mbar l/s	155 80

# Connection Components

When connecting accessories (helium sniffer probe and calibrated leaks) to a vacuum leak detector, the following reducers and components may be necessary:

## ORDERING INFORMATION

	PART NUMBER
Reducers, stainless steel / FPM	
DN 25 / 16 KF	211-281
DN 40 / 25 KF	211-283
DN 40 / 16 KF	211-282
Centering rings	
DN 16 KF	211-059
DN 25 KF	211-068
DN 40 KF	211-070
Clamping rings	
DN 16 KF	211-001
DN 25 KF	211-002
DN 40 KF	211-003

The following metal hoses are recommended to connect the leak detectors to systems:

Nominal Width	Length	PART NUMBER
DN 16 KF	1.0 m	211-338
DN 16 KF	0.5 m	211-336
DN 25 KF	1.0 m	211-342
DN 25 KF	0.5 m	211-340
DN 40 KF	1.0 m	211-346
DN 40 KF	0.5 m	211-344

# Helium Sniffer Leak Detector Protec P3000(XL)

INFICON Protec P3000 and Protec P3000XL Helium Sniffer Leak Detectors are specifically designed for full-time sniffing applications in demanding production environments.

The Protec P3000(XL) brings increased levels of productivity and reliability to the sub-assembly and midproduction testing of refrigerators, freezers, air conditioners, automotive air conditioners, RAC components and similar products. Numerous features make it easy and comfortable to use, while making it more immune to careless or untrained operation. It is also fast to make the best use of your available cycle time. Protec P3000(XL) uses innovative INFICON Wise Technology in this robust, reliable and maintenance-free sensor. The Wise Technology sensor combined with the unique design and ruggedness of the leak detector, provides a very low cost of ownership and high up-time.



## USER ADVANTAGES

- Improved system design compensates for operator error reducing the potential for missed leaks.
- Protec P3000 provides the minimum detectable leak rate on the market.
- Protec P3000XL is unique for detecting leaks at a considerable distance.
- A small display in the ergonomically-designed probe handle shows the leak rate, so the operator can concentrate on the sniffing process and monitoring the leak rate at the same time.
- Built-in illumination source of the probe helps precisely position the sniffer tip.
- Multiple alarm functions make sure alarms cannot be overlooked.
- Built-in PRO-Check reference leak allows for easy and fast calibration at the production line at any time.
- I-Guide mode ensures your operator is testing the right locations with the correct technique.
- Leak rates can be displayed in refrigerant equivalents from a gas library.
- New, low-maintenance sensor yields high reliability and low cost of ownership.
- Automatic standby prevents intake of contaminants into the sniffer probe, thus saving filter and sensor life.
- Operating software is available in many languages.

## TYPICAL APPLICATIONS

The Protec P3000 is ideal for all helium sniffing applications of pressurized components that need to be leak tested.

- Refrigerating / air conditioning industries
  - Evaporators
  - Condensers
  - Valves
  - Compressors
  - Testing of pre-assembled air condition systems before filling with refrigerant
  - Testing of pre-assembled refrigerators and freezers before filling with refrigerant
  - Testing of pre-assembled heat pump systems before filling with refrigerant
- Automotive industry
  - Brake lines
  - Fuel lines
  - Hydraulic components
  - Engines
  - Testing of pre-assembled air conditioning systems before filling with refrigerant



Protec P3000RC  
with external display unit for rack mounting

SPECIFICATIONS	PROTEC P3000	PROTEC P3000(XL)
Minimum detectable leak rate	1 x 10 <sup>-7</sup> mbarl/s	1x10 <sup>-6</sup> mbarl/s @ 3000 sccm 1x10 <sup>-7</sup> mbarl/s @ 300 sccm
Measuring scale	5 decades	4 decades @ 3000 sccm 5 decades @ 300 sccm
Sensor response time	450 ms	
Response time incl. sniffer line	< 0.7s	
Leak rate units	mbar l/s; Pa m <sup>3</sup> /s; ppm	
Refrigerant equivalent leak rates	g/a; oz/yr; lb/yr	
Start-up time	approx. 5 min	
Dimensions (width x depth x height)	610 x 265 x 370 mm (24 x 10.4 x 14.6 in)	
Weight	27 kg (60 lbs)	
Gas flow	300 sccm	300 / 3000 sccm
Ambient temperature range	10-45°C (50-113°F)	

## ORDERING INFORMATION

	PART NUMBER		PART NUMBER
Protec P3000		Sniffer tips for SL3000 (Protec P3000)	
230 V, 50 Hz	520-001	ST 312, 120 mm, rigid	12213
100/115 V, 50/60 Hz	520-002	FT 312, 120 mm, flexible	12214
Protec P3000XL		ST 200, 200 mm, rigid	12218
230 V, 50 Hz	520-003	FT 250, 250 mm, flexible	12266
100/115, 50/60 Hz	520-004	ST 385, 385 mm, rigid	12215
Remote controlled version		FT 385, 385 mm, flexible	12216
Protec P3000, RC, 230 V, 50 Hz	520-103	FT 600, 600 mm, flexible	12209
Protec P3000, RC, 110/115 V, 50/60 Hz	520-104	ST 400, 400 mm, 45° angled	12272
Protec P3000XL, RC, 230 V, 50 Hz	520-105	Sniffer tips for SL3000XL (Protec P3000XL)	
Protec P3000XL, RC, 110/115 V, 50/60 Hz	520-106	ST312XL, 120 mm, rigid	12280
Sniffer line for Protec P3000		FT312XL, 120mm, flexible	12281
with integrated display and push-buttons		ST385XL, 385 mm, rigid	12282
SL3000-3, 3 m length	525-001	FT385XL, 385 mm, flexible	12283
SL3000-5, 5 m length	525-002	FT250XL, 250 mm, flexible	12285
SL3000-10, 10 m length	525-003	Holder for sniffer probe	525-006
SL3000-15, 15 m length	525-004	PRO-Check reference leak - Optional (Not included with delivery of Protec P3000)	521-001
Sniffer line for Protec P3000XL		Spare reservoir for PRO-Check	521-010
with integrated display and push-buttons		Display unit for Protec P3000RC	
SL3000XL-3, 3 m length	521-011	Table top version	551-100
SL3000XL-5, 5 m length	521-012	Rack version	551-101
SL3000XL-10, 10 m length	521-013	Connecting cable for display unit	
SL3000XL-15, 15 m length	521-014	5 m length	551-102
Sniffer line adapter for system integration		0.7 m length	551-103
for Protec P3000	525-005		
for Protec P3000XL	521-015		

Protec and Wise Technology are trademarks of INFICON.

# Multi-Gas Sniffer Leak Detector Ecotec E3000

The Ecotec E3000 leak detector brings new levels of productivity and reliability to the final testing of refrigerators, freezers, automotive air conditioners and similar products. It is specifically designed for demanding production environments. Numerous features make it easy and comfortable to use while making it more immune to careless operation and minimizing operator errors. It is also fast to make the best use of your available cycle time. Innovative design and robustness keep the cost of ownership down and ensure very high up-time.

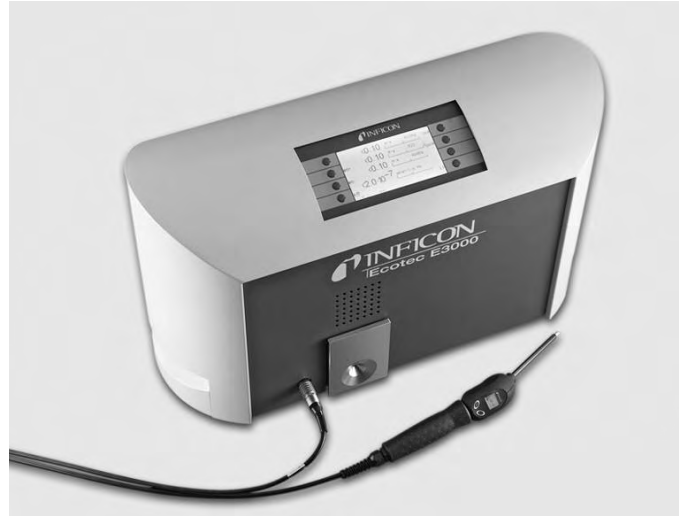

## USER ADVANTAGES

- Improved system design compensates for poor sniffing operation reducing the potential for missed leaks
- IGS (Interfering Gas Suppression) ensures only leaks are detected
- Built-in illumination source on the probe helps precisely position the sniffer tip
- Unit can be operated via the probe display and probe buttons without access to the main unit
- Built-in ECO-Check reference leak allows for easy and fast calibration at the production line at any time
- Multiple alarm functions make sure alarms cannot be overlooked
- I-Guide (operator guiding mode) ensures your operator tests the right locations with the right technique
- Ergonomic probe design allows for easy and comfortable use
- Operating software is available in many languages

## TYPICAL APPLICATIONS

- Refrigerators and freezers
- Transportation refrigeration
- Cooling and refrigeration systems
- Air conditioning units
- Water coolers
- Compressors and evaporators
- Halogen lamps
- Gas panels



Ecotec E3000RC  
with external display unit for table top use

SPECIFICATIONS		ECOTEC E3000
Minimum detectable leak rate	R134a R600a Helium	0.05 g/a (0.002 oz/yr) 0.05 g/a (0.002 oz/yr) 1 x 10 <sup>-6</sup> mbar l/s
Measuring scale		0.05 – 999.99 g/a (0.015 – 99.999 oz/yr)
Sensor response time		0.3 s
Response time incl. sniffer line		0.8 s
Max no. of gases detected simultaneously		4
Leak rate units		g/a, oz/y, mbar l/s, ppm, Pa m <sup>3</sup> /s
Gas flow		160 sccm
Start-up time		< 2 min
Ambient temperature range		10 – 45 °C (50 – 113 °F)
Dimensions (W x H x D)		610 x 370 x 265 mm (24 x 14.6 x 10.4 in)
Weight		34 kg (75 lbs)
ORDERING INFORMATION		PART NUMBER
Ecotec E3000, 230 V, 50 Hz 100/115 V, 50/60 Hz		530-001 530-002
Ecotec E3000RC 230 V, 50 Hz 100/115 V, 50/60 Hz		530-103 530-104
Sniffer line with integrated display and push-buttons SL3000-3, 3 m length SL3000-5, 5 m length SL3000-10, 10 m length SL3000-15, 15 m length		525-001 525-002 525-003 525-004
Sniffer line adapter for system integration		525-005
Sniffer tips ST 312, 120 mm, rigid FT 312, 120 mm, flexible ST 200, 200 mm, rigid FT 250, 250 mm, flexible ST 385, 385 mm, rigid FT 385, 385 mm, flexible FT 600, 600 mm, flexible ST 400, 400 mm, 45° angled		122 13 122 14 122 18 122 66 122 15 122 16 122 09 122 72
Holder for sniffer probe		525-006
ECO-Check reference leak R134a - optional (Not included with delivery of Ecotec E3000.)		531-001
Display unit for Ecotec E3000RC Table top version Rack version		551-100 551-101
Connecting cable for display unit 5 m 0.7 m		551-102 551-103
Test leaks for refrigerants (2 - 5 g/a) R134a R600a R404A R502 R22 R152a R407C R410A R401a R290 Forming gas (10% hydrogen, 90% helium) Halon 1301		122 20 122 21 122 22 122 23 122 25 122 27 122 28 122 29 122 30 122 31 122 33 122 34

# Multi-Gas Leak Detector Ecotec E3000A

The Ecotec E3000A multi-gas leak detector is the reliable and low-cost solution for testing cooling circuits in airplanes. Simpler and measurably faster than conventional leak-testing methods, the Ecotec E3000A does not require evacuation. It simply “sniffs” for refrigerant leaks while the system is in use, reducing downtime and waste.

It comes with a library of more than 100 detectable gases including all refrigerants and heat transfer fluids used in Airbus airplanes as well as many other commonly used gases.

The Ecotec E3000A is officially recommended for use in the A340 (for more information see AMM A340 chapter 25) and the next-generation A380 (AMM A380 chapter 21).



## USER ADVANTAGES

- Improved system design compensates for poor sniffing operation reducing the potential for missed leaks
- Built-in, adjustable illumination helps operators precisely position the tip even in tight compartments where light is limited
- Simpler and measurably faster than conventional testing methods
- Does not require evacuation
- Less downtime for airplanes
- Fewer instances where food cannot be served because of refrigeration issues, resulting in better customer service
- Pinpoints the exact location of the leak
- Detected leak rate can be read from the probe display as numerical value
- Can detect up to four different gases at the same time
- Wheeled transportation case that holds all accessories to be easily hauled around the airplane
- Recommended in AMM A340, Chapter 25 and AMM A380, Chapter 21

## TYPICAL APPLICATIONS

Leak testing of

- Galley systems
- Transfer lines
- Main chiller system
- Air conditioning system
- Fire extinguishing system

SPECIFICATIONS	ECOTEC E3000A
Minimum detectable leak rate	0.05 g/a (0.02 oz/yr)
Measuring scale	0.5 – 50 g/a (0.02 – 1.76 oz/yr)
Response time	< 1s
Leak rate units	g/a; oz/yr; lb/yr; mbar l/s; Pa m <sup>3</sup> /s
Start-up time	< 2 min
Max no. of gases detected simultaneously	4
Interfaces	RS232
Dimensions (diameter; height)	580 x 260 x 350 mm (22.8 x 12.2 x 13.8 in)
Weight	34 kg (75 lbs)
Gas flow	160 sccm
Ambient temperature range	10-45 °C (50-113 °F)
Software available in	English, German, Spanish, French, Italian, Portugese, Chinese, Japanese (Katakana)
Warranty	2 years
ORDERING INFORMATION	PART NUMBER
<p>Ecotec E3000A including:</p> <p>5 m sniffer line, power plug adapter for all major regions,  120 mm rigid sniffer tip, 385 mm flexible sniffer tip,  built-in ECO-Check reference leak, transportation case  230 V, 50 Hz  100/115 V, 50/60 Hz</p>	<p>530-101  530-102</p>

# Refrigerant Sniffer Leak Detector HLD5000

The HLD5000 refrigerant leak detector uses an innovative technology to find leaks quickly and reliably with dramatically fewer false alarms.

With its IR sensor it is designed to only detect refrigerant leaks. It reliably suppresses any signals caused by other gases present in the atmosphere. Numerous other features enhance the units convenience, reliability and durability. A selection of probes for single gases as well as a universal probe for all halogen-based refrigerants is available.

The present HLD5000 is the best leak detector in its class.



## USER ADVANTAGES

### Highly reliable detection of leaks

- No false alarms due to background compensation by dual inlet technology
- No cross sensitivity to non-halogens (water, breath, alcohols, etc)
- No undetected leaks due to undetected malfunctioning of the leak detector as functionality is constantly monitored
- Short response time for fast use

### Universal base unit for high flexibility

- Universal base unit with different probes
- Selection of different probes for single refrigerants including non-halogens (CO<sub>2</sub>, SF<sub>6</sub>)
- Universal probe for all halogen-based refrigerants
- Unit can be switched over by simply connecting a different sniffer line

### Easy to operate

- ATM-like display
- Visual (probe and base unit) and acoustic alarm
- Integrated test leak for easy and traceable calibration at the line as well as regular verification of the calibration
- May be used in automated testing systems with digital processing of test data via RS232 interface

### Low cost of operation

- Reliable operation of the unit and very low cost of operation
- Long sensor life, resistant to water intake

## TYPICAL APPLICATIONS

- Air conditioning systems
- Automotive air conditioning units
- Heat pumps
- Compressors and tubing
- CO<sub>2</sub> components
- Components or systems filled with SF<sub>6</sub>

SPECIFICATIONS		HLD5000
Detectable refrigerant	single gas probe universal Smart Probe	R134a; R744 (CO <sub>2</sub> ), SF <sub>6</sub> all halogen-based refrigerants
Minimum detectable leak rate	single gas probe universal Smart Probe	g/a (0.03 oz/yr) 0.5 g/a (0.014 oz/yr)
Measuring scale	single gas probe universal Smart Probe	0 - 100 g/a (3.57 oz/yr) 0 - 300 g/a (10.7 oz/yr)
Response time		< 1 s
Leak rate units		g/a; mbar l/s; oz/yr; lb/yr; Pa m <sup>3</sup> /s
Warm-up time		30 s
Dimensions (diameter; height)		260 mm (10.25 in.); 365 mm (14.4 in.)
Weight		4.5 kg (10 lb.)
Length of sniffer line		4.8 m (15.5 ft.)
Standard sniffer tip length		100 mm (3.9 in.)
Gas flow		320 sccm
Ambient temperature range		5 - 50°C (40 - 120°F)

ORDERING INFORMATION	PART NUMBER
HLD5000, includes complete sniffer probe (4.8 m / 15.5 ft) with standard sniffer tip (100 mm / 3.9 in.) and COOL-Check reference leak	
R134a	510-010
R744 (CO <sub>2</sub> )	510-015
SF <sub>6</sub>	510-016
Universal Smart probe	510-037
Additional sniffer probes sold separately	
R134a	511-030
R744 (CO <sub>2</sub> )	511-035
SF <sub>6</sub>	511-036
Universal Smart probe	511-037
Options, Accessories	
Sniffer tip, 100 mm (3.9 in.)	511-021
Sniffer tip, 400 mm (15 in.)	511-024
Sniffer tip, 400 mm (15 in.), prebent to half circle	511-022
Extension, 400 mm (15.7 in.) for sniffer tip	511-020
Extension, 500 mm (19.7 in.) for sniffer tip, 45° offset	511-029
Water protection tip	511-025
Extension for probe cable, 4.8m (15.5 ft)	511-040
Adapter for R744 (CO <sub>2</sub> ) calibration <sup>1</sup>	511-042
Consumables	
Set of tip filter holders (20 pcs.)	511-027
Set of silicone filter cartridges	511-018
Replacement COOL-Check reference leak <sup>2</sup>	511-010

<sup>1</sup> included in delivery of HLD5000 for CO<sub>2</sub> (511-015).

<sup>2</sup> limited shelf life, purchase only when needed.

# Calibrated Test Leaks for Sniffer Applications

The function of these leaks is based on a special quartz capillary which is customized to deliver a specific reduced flow from a test gas reservoir.

This type of calibrated test leaks is available in different leak rates and test gases (see ordering information).



## USER ADVANTAGES

- Highly accurate and reliable due to the profile of the quartz capillary
- Metal-free capillary for low temperature dependance
- Inspection certificate (included) in accordance to DIN EN 10204:2004-3.1
- Determination of the nominal leak rate by comparison with a calibrated leak having a PTB certificate
- DKD certificate (optional) traceable to PTB

## ORDERING INFORMATION

CALIBRATED LEAK	LEAK RATE RANGE	PART NUMBER
S-TL 4, with helium gas reservoir	10 <sup>-4</sup> mbar l/s	122 37
S-TL 5, with helium gas reservoir	10 <sup>-5</sup> mbar l/s	122 38
S-TL 6, with helium gas reservoir	10 <sup>-6</sup> mbar l/s	122 39
Calibrated sniffer test leaks for refrigerants		
2 - 5 g/a, 0.07 - 0.18 oz/y		
R22		122 25
R134a		122 20
R152a		122 27
R290		122 31
R401a		122 30
R404a		122 22
R407c		122 28
R410a		122 29
R502		122 23
R600a		122 21
R744 (CO <sub>2</sub> )		122 32
10% H <sub>2</sub> / 90% H		122 33
R13B1 (Halon 1301)		122 34
10 - 14 g/a, 0.36 - 0.5 oz/y		
R134a		122 40
R404a		122 42
R502		122 43
R600a		122 41





[www.inficon.com](http://www.inficon.com) [reachus@inficon.com](mailto:reachus@inficon.com)

Due to our continuing program of product improvements, specifications are subject to change without notice.

mla0141g (0904) ©2009 INFICON